

E

**Geotechnical
Investigations**

This page intentionally left blank.

GEOTECHNICAL INVESTIGATION

**TORREY CREST
1220-1240 MELBA ROAD AND
1190 ISLAND VIEW LANE
ENCINITAS, CALIFORNIA**



GEOCON
INCORPORATED

GEOTECHNICAL
ENVIRONMENTAL
MATERIALS

PREPARED FOR

**TORREY PACIFIC CORPORATION
ENCINITAS, CALIFORNIA**

**APRIL 5, 2023
PROJECT NO. G2438-52-01**



Project No. G2438-52-01
April 5, 2023

Torrey Pacific Corporation
171 Saxony Road, Suite 109
Encinitas, California 92024

Attention: Mr. Brian Staver

Subject: GEOTECHNICAL INVESTIGATION
TORREY CREST
1220-1240 MELBA ROAD AND 1190 ISLAND VIEW LANE
ENCINITAS, CALIFORNIA

Dear Mr. Staver:

In accordance with your request and authorization of our Proposal No. LG-19293 dated August 7, 2019, we herein submit the results of our geotechnical investigation for the subject project. We performed our investigation to evaluate the underlying soil and geologic conditions and potential geologic hazards, and to assist in the design of the proposed residential subdivision.

The accompanying report presents the results of our study and conclusions and recommendations pertaining to geotechnical aspects of the proposed project. The site is suitable for the proposed residential development improvements provided the recommendations of this report are incorporated into the design and construction of the planned project.

Should you have questions regarding this report, or if we may be of further service, please contact the undersigned at your convenience.

Very truly yours,

GEOCON INCORPORATED

Michael C. Ertwine
CEG 2659

MCE:SFW:am

(e-mail) Addressee



Shawn Foy Weedon
GE 2714



TABLE OF CONTENTS

| | |
|--|----|
| 1. PURPOSE AND SCOPE | 1 |
| 2. SITE AND PROJECT DESCRIPTION..... | 2 |
| 3. GEOLOGIC SETTING | 3 |
| 4. SOIL AND GEOLOGIC CONDITIONS | 4 |
| 4.1 Topsoil (unmapped)..... | 4 |
| 4.2 Very Old Paralic Deposits (Qvop)..... | 5 |
| 4.3 Torrey Sandstone (Tt)..... | 5 |
| 5. GROUNDWATER | 5 |
| 6. GEOLOGIC HAZARDS | 5 |
| 6.1 Faulting and Seismicity | 5 |
| 6.2 Ground Rupture..... | 7 |
| 6.3 Liquefaction..... | 7 |
| 6.4 Storm Surge, Tsunamis, and Seiches | 7 |
| 6.5 Subsidence..... | 7 |
| 6.6 Landslides..... | 8 |
| 6.7 Erosion..... | 8 |
| 7. CONCLUSIONS AND RECOMMENDATIONS | 9 |
| 7.1 General | 9 |
| 7.2 Excavation and Soil Characteristics | 10 |
| 7.3 Grading..... | 11 |
| 7.4 Subdrains..... | 15 |
| 7.5 Temporary Excavations..... | 15 |
| 7.6 Seismic Design Criteria – 2019 California Building Code | 15 |
| 7.7 Preliminary Foundation and Concrete Slabs-On-Grade Recommendations | 17 |
| 7.8 Exterior Concrete Flatwork | 23 |
| 7.9 Retaining Walls | 24 |
| 7.10 Lateral Loading | 27 |
| 7.11 Preliminary Pavement Recommendations..... | 28 |
| 7.12 Site Drainage and Moisture Protection..... | 31 |
| 7.13 Grading and Foundation Plan Review..... | 32 |
| 7.14 Testing and Observation Services During Construction | 32 |

LIMITATIONS AND UNIFORMITY OF CONDITIONS

MAPS AND ILLUSTRATIONS

Figure 1, Geologic Map
Figure 2, Geologic Cross-Sections

APPENDIX A FIELD INVESTIGATION

APPENDIX B LABORATORY TESTING RESULTS

APPENDIX C RECOMMENDED GRADING SPECIFICATIONS

LIST OF REFERENCES

GEOTECHNICAL INVESTIGATION

1. PURPOSE AND SCOPE

This report presents the results of our geotechnical investigation for a new 30 lot residential subdivision located in Encinitas, California (see Vicinity Map). The purpose of the geotechnical investigation is to evaluate the surface and subsurface soil conditions and general site geology, and to identify geotechnical constraints that may affect development of the property including faulting, liquefaction and seismic shaking based on the 2019 CBC seismic design criteria. In addition, we provided recommendations for remedial grading, shallow foundations, concrete slab-on-grade, concrete flatwork, pavement, and retaining walls.



Vicinity Map

We reviewed the following plans and report in preparation of this report:

1. *Limited Geotechnical Investigation, Oak Crest Middle School, 675 Balour Drive, Encinitas, California*, prepared by Geocon Incorporated, dated August 26, 2013 (Project No. G1571-42-01).
2. *Preliminary Grading Plan for: Torrey Crest, 1220-1240 Melba Road and 1190 Island View Lane*, prepared by Pasco, Laret, Suiter & Associates, (PLSA 3086-01), received March 29, 2023.
3. *Concept Site Plan, Melba Road SFD, Encinitas, California*, prepared by JZMK Partners, dated October 22, 2020 (JZMK #202019).

The scope of this investigation included reviewing readily available published and unpublished geologic literature (see List of References); performing engineering analyses; and preparing this report. We also

advanced 11 exploratory trenches (Trenches T -1 through T-11 and P-1 through P-4) to a maximum depth of about 7 feet, performed percolation/infiltration testing, sampled soil and performed laboratory testing. Appendix A presents the exploratory boring logs and details of the field investigation. The details of the laboratory tests and a summary of the test results are shown in Appendix B and on the boring logs in Appendix A.

2. SITE AND PROJECT DESCRIPTION

The property is located north of Melba Road and east of the Island View Lane terminus in the City of Encinitas, California. The subject project site is occupied by four single-family residences with accompanied ancillary structures, utilities, landscaping and driveways. The property is accessed by two driveways from Melba Road and a driveway from Island View Lane. The topography is relatively flat to gently sloping at an elevation of about 370 to 400 feet above mean sea level (MSL). The Existing Site Plan shows the current site conditions.

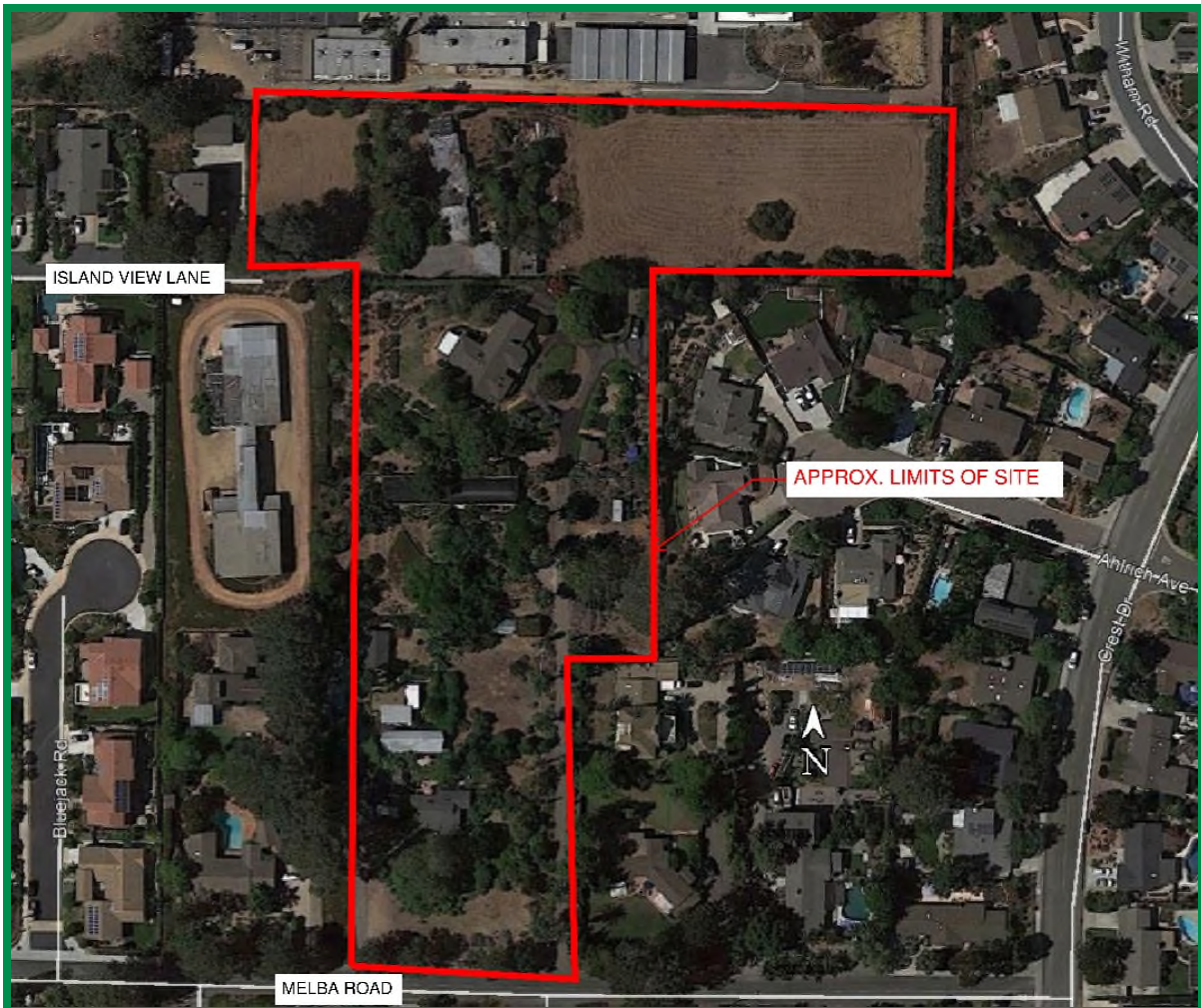

Existing Site Plan

Based on a referenced current plan prepared by PLSA, we understand the project will consist of demolishing the existing structures, removing the existing utilities, and constructing a new residential development. The new development would consist of 30 single-family residences with associated utilities, landscape roadway, cul-de-sac, basin and access driveways. The development would be accessed by a private road from Melba Road with a cul-de-sac on the north end. A bioretention basin is planned on the southwestern, and northeast portions of the property. We understand the northwest basin will outlet to the existing storm drain easement in the brow ditch to the east. We expect the proposed residences would be supported on conventional shallow foundations consisting of post-tensioned slabs.

The locations, site descriptions, and proposed development are based on our geotechnical investigation, review of published geologic literature, field investigations, and discussions with project personnel. If development plans differ from those described herein, Geocon Incorporated should be contacted for review of the plans and possible revisions to this report.

3. GEOLOGIC SETTING

Regionally, the site is located in the Peninsular Ranges geomorphic province. The province is bounded by the Transverse Ranges to the north, the San Jacinto Fault Zone on the east, the Pacific Ocean coastline on the west, and the Baja California on the south. The province is characterized by elongated northwest-trending mountain ridges separated by straight-sided sediment-filled valleys. The northwest trend is further reflected in the direction of the dominant geologic structural features of the province that are northwest to west-northwest trending folds and faults, such as the nearby Rose Canyon fault zone.

Locally, the site is within the coastal plain of San Diego County. The coastal plain is underlain by a thick sequence of relatively undisturbed and non-conformable sedimentary bedrock units that thicken to the west and range in age from Upper Cretaceous age through the Pleistocene age which have been deposited on Cretaceous to Jurassic age igneous and volcanic bedrock. Geomorphically, the coastal plain is characterized by a series of twenty-one, stair-stepped marine terraces (younger to the west) that have been dissected by west flowing rivers. The coastal plain is a relatively stable block that is dissected by relatively few faults consisting of the potentially active La Nacion Fault Zone and the active Rose Canyon Fault Zone.

The site is located on the western portion of the coastal plain. Marine sedimentary units make up the geologic sequence encountered on the site and consist of middle to early Pleistocene-age Very Old Paralic Deposits (formerly known as Terrace Deposits). The Very Old Paralic Deposits are shallow marine deposits generally consisting of sand and silty sand units interfingering with layers of silt and clay. This unit may be in excess of 50 feet thick underlain by the Torrey Sandstone. The Regional Geologic Map shows the geologic units in the area of the site.



Regional Geologic Map

4. SOIL AND GEOLOGIC CONDITIONS

During our field investigation, we encountered one surficial soil unit (consisting of topsoil) and two formational units (consisting of Very Old Paralic Deposits and the Torrey Sandstone). The occurrence, distribution, and description of topsoil and geologic unit encountered are shown on the Geologic Map, Figure 1 and on the trench logs in Appendix A. The Geologic Cross-Sections, Figure 2, show the approximate subsurface relationship between the geologic units. We prepared the geologic cross-sections using interpolation between exploratory excavations and observations; therefore, actual geotechnical conditions may vary from those illustrated and should be considered approximate. The surficial soil and geologic units are described herein in order of increasing age.

4.1 Topsoil (unmapped)

We encountered Holocene-age topsoil present as a relatively thin veneer locally blanketing the geologic unit across the site. The topsoil is less than a foot to two feet thick across the site and can be characterized as loose, damp to dry, reddish to grayish brown, silty, fine to medium sand. The topsoil is compressible and possess a “very low” expansion potential (expansion index of 20 or less). Remedial grading of the topsoil will be necessary in areas to support proposed fill or structures. The topsoil can be reused for new compacted fills. Water that is allowed to migrate within the topsoil cannot be controlled, would destabilize support for the existing improvements, and would shrink and swell. Therefore, full and partial infiltration should not be allowed within the topsoil.

4.2 Very Old Paralic Deposits (Qvop)

Quaternary-age Very Old Paralic Deposits, Unit 10 (formerly called the Terrace Deposits) underlies the topsoil and extended to the maximum depth explored of 7 feet. The Very Old Paralic Deposits consists of a sandstone unit consists of dense to very dense sandstone. We encountered practical trenching refusal in the dense sandstone materials in the exploratory borings, where encountered. The sandstone unit within the Very Old Paralic Deposits possess a “very low” expansion potential (expansion index of 20 or less). Excavations within this unit will likely encounter difficult digging conditions in the cemented zones.

4.3 Torrey Sandstone (Tt)

Torrey Sandstone likely underlies the Very Old Paralic Deposits at an elevation of about 330 feet MSL. The Torrey Sandstone consists of a very dense sandstone and excavates as silty, fine to medium sand. We did not encounter this unit during our exploratory excavations. We expect the sandstone unit possesses a “very low” expansion potential (expansion index of 20 or less). We should not encounter this unit during the construction operations.

5. GROUNDWATER

We did not encounter groundwater or seepage during our site investigation. However, it is not uncommon for shallow seepage conditions to develop where none previously existed when sites are irrigated or infiltration is implemented. Seepage is dependent on seasonal precipitation, irrigation, land use, among other factors, and varies as a result. Proper surface drainage will be important to future performance of the project. We expect groundwater is deeper than about 150 feet below existing grade. We do not expect groundwater to be encountered during construction of the proposed development.

6. GEOLOGIC HAZARDS

6.1 Faulting and Seismicity

A review of the referenced geologic materials and our knowledge of the general area indicate that the site is not underlain by active, potentially active, or inactive faults. An active fault is defined by the California Geological Survey (CGS) as a fault showing evidence for activity within the last 11,700 years. The site is not located within the State of California Earthquake Fault Zone.

The USGS has developed a program to evaluate the approximate location of faulting in the area of properties. The following figure shows the location of the existing faulting in the San Diego County and Southern California region. The fault traces are shown as solid, dashed and dotted that represent well-constrained, moderately constrained and inferred, respectively. The fault line colors represent faults with ages less than 150 years (red), 15,000 years (orange), 130,000 years (green), 750,000 years (blue) and 1.6 million years (black).

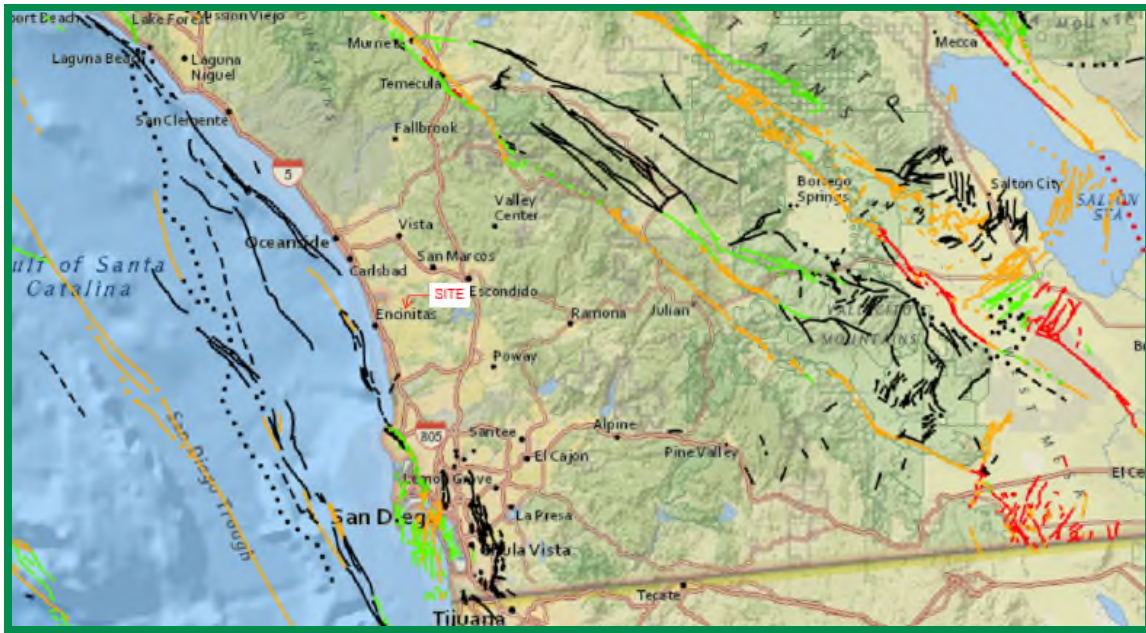

Faults in Southern California

The San Diego County and Southern California region is seismically active. The following figure presents the occurrence of earthquakes with a magnitude greater than 2.5 from the period of 1900 through 2015 according to the Bay Area Earthquake Alliance website.

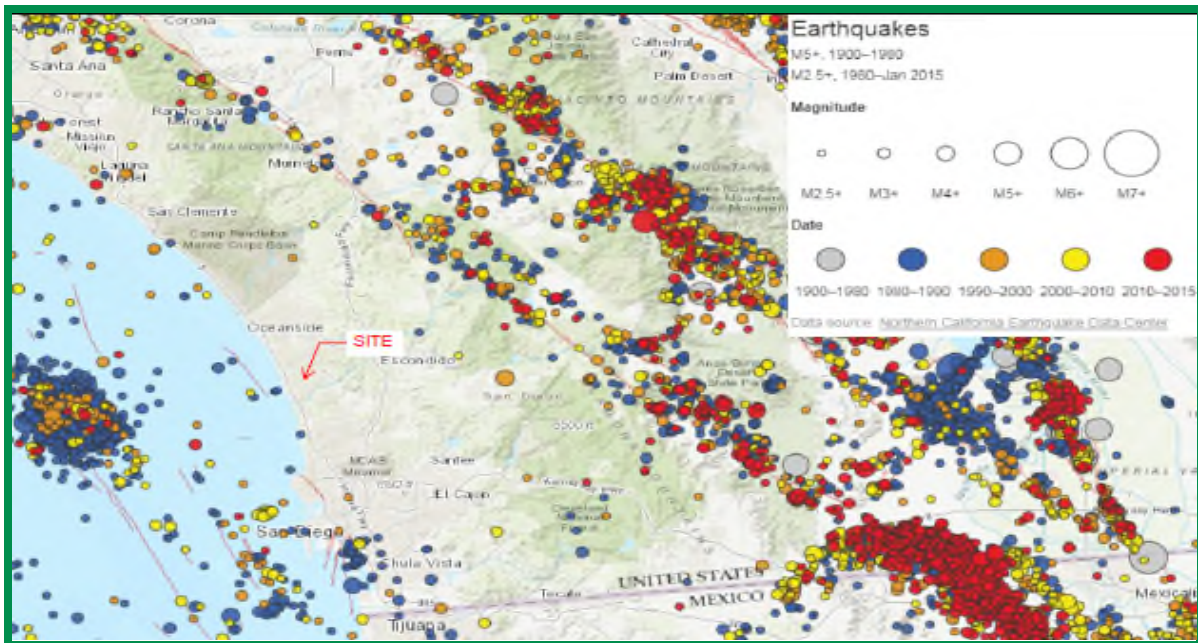

Earthquakes in Southern California

Considerations important in seismic design include the frequency and duration of motion and the soil conditions underlying the site. Seismic design of structures should be evaluated in accordance with the California Building Code (CBC) guidelines currently adopted by the local agency.

6.2 Ground Rupture

Ground surface rupture occurs when movement along a fault is sufficient to cause a gap or rupture where the upper edge of the fault zone intersects the ground surface. The potential for ground rupture is considered to be very low due to the absence of active faults at the subject site.

6.3 Liquefaction

Liquefaction typically occurs when a site is located in a zone with seismic activity, onsite soils are cohesionless or silt/clay with low plasticity, groundwater is encountered within 50 feet of the surface and soil densities are less than about 70 percent of the maximum dry densities. If the four previous criteria are met, a seismic event could result in a rapid pore water pressure increase from the earthquake-generated ground accelerations. Due to the lack of a permanent, near-surface groundwater table and the very dense nature of the underlying Very Old Paralic Deposits, liquefaction potential for the site is considered very low.

6.4 Storm Surge, Tsunamis, and Seiches

Storm surges are large ocean waves that sweep across coastal areas when storms make landfall. Storm surges can cause inundation, severe erosion and backwater flooding along the water front. The site is located approximately 4 miles from the Pacific Ocean and at an elevation of about 370 feet to 400 feet above mean sea level (MSL). Therefore, the potential of storm surges affecting the site is considered low.

A tsunami is a series of long period waves generated in the ocean by a sudden displacement of large volumes of water. Causes of tsunamis include underwater earthquakes, volcanic eruptions, or offshore slope failures. We consider the risk of a tsunami hazard at the site to be low due the site elevations and the distance from the Pacific Ocean.

A seiche is a run-up of water within a lake or embayment triggered by fault- or landslide-induced ground displacement. The site is not located near an inland body of water; therefore, we consider the potential for seiches to impact the site low.

6.5 Subsidence

Subsidence occurs when a large portion of land is displaced vertically, usually due to the withdrawal of groundwater, oil or natural gas. Soil particularly subject to subsidence include those with high silt or

clay content. The site is not located within an area of known ground subsidence. We understand known large-scale extraction of groundwater, gas, oil or geothermal energy is not occurring or planned at the site or in the general site vicinity. Therefore, the potential for ground subsidence due to withdrawal of fluids or gases at the site is considered low.

6.6 Landslides

We did not observe evidence of previous or incipient slope instability at the site during our study and the property is relatively flat. Published geologic mapping indicates landslides are not present on or adjacent to the site. Therefore, in our professional opinion, the potential for a landslide is not a significant concern for this project.

6.7 Erosion

The site is relatively flat and is not located adjacent to the Pacific Ocean coast or a free-flowing drainage where active erosion is occurring. Provided the engineering recommendations herein are followed and the project civil engineer prepares the grading plans in accordance with generally-accepted regional standards, we do not expect erosion to be a major impact to site development.

7. CONCLUSIONS AND RECOMMENDATIONS

7.1 General

- 7.1.1 We did not encounter soil or geologic conditions during our exploration that would preclude the proposed development, provided the recommendations presented herein are followed and implemented during design and construction. We will provide supplemental recommendations if we observe variable or undesirable conditions during construction, or if the proposed construction will differ from that anticipated herein.
- 7.1.2 Potential geologic hazards at the site include seismic shaking, bentonitic claystone and siltstone layers, and expansive and compressible soil. Based on our investigation, testing and observations during previous mass grading operations, and available geologic information, active, potentially active, or inactive faults are not present underlying or trending toward the site.
- 7.1.3 Topsoil blankets the site and is potentially compressible and unsuitable in its present condition for the support of compacted fill or settlement-sensitive improvements. Remedial grading of these materials should be performed as discussed herein. The dense portions of the Very Old Paralic Deposits and Torrey Sandstone are considered suitable for the support of proposed fill and structural loads. We should not encounter the Torrey Sandstone unit during the grading operations.
- 7.1.4 We did not encounter groundwater during our subsurface exploration and we do not expect it to be a constraint to project development. However, seepage within surficial soils and rock materials may be encountered during the grading operations, especially during the rainy seasons.
- 7.1.5 Proper drainage should be maintained in order to preserve the engineering properties of the fill in both the building pads and slope areas. Recommendations for site drainage are provided herein.
- 7.1.6 We will prepare a storm water management investigation under a separate report to help evaluate the potential for infiltration on the property. The project civil engineer should use that report to help design the storm water management devices.
- 7.1.7 Based on our review of the project plans, we opine the planned development can be constructed in accordance with our recommendations provided herein. We do not expect the planned development will destabilize or result in the settlement of adjacent properties if properly constructed.

- 7.1.8 The site is considered suitable for the use of conventional continuous and spread footings with a concrete slab-on-grade system or a post-tensioned foundation system.
- 7.1.9 The building pads should be graded such that at least the upper 3 feet of materials below proposed pad grade are composed of compacted fill. The undercut bottoms should be sloped to drain away from the building pads and toward adjacent streets or toward the deeper fill areas.
- 7.1.10 Surface settlement monuments and canyon subdrains will not be required on this project.

7.2 Excavation and Soil Characteristics

7.2.1 The soil encountered in the field investigation is considered to be “non-expansive” (expansion index [EI] of 20 or less) as defined by 2019 California Building Code (CBC) Section 1803.5.3. Table 7.2 presents soil classifications based on the expansion index. We expect a majority of the soil encountered possess a “very low” to “low” expansion potential (EI of 50 or less).

**TABLE 7.2
EXPANSION CLASSIFICATION BASED ON EXPANSION INDEX**

| Expansion Index (EI) | ASTM D 4829 Expansion Classification | 2019 CBC Expansion Classification |
|----------------------|---|--------------------------------------|
| 0 – 20 | Very Low | Non-Expansive |
| 21 – 50 | Low | Expansive |
| 51 – 90 | Medium | |
| 91 – 130 | High | |
| Greater Than 130 | Very High | |

- 7.2.2 We performed a laboratory test on a sample of the site materials to evaluate the percentage of water-soluble sulfate content. Appendix B presents the results of the laboratory water-soluble sulfate content test. The test results indicate the on-site materials at the location tested possesses “S0” sulfate exposure to concrete structures as defined by 2019 CBC Section 1904 and ACI 318-14 Chapter 19. The presence of water-soluble sulfates is not a visually discernible characteristic; therefore, other soil samples from the site could yield different concentrations. Additionally, over time landscaping activities (i.e., addition of fertilizers and other soil nutrients) may affect the concentration.
- 7.2.3 Geocon Incorporated does not practice in the field of corrosion engineering. Therefore, further evaluation by a corrosion engineer may be performed if improvements susceptible to corrosion are planned.

7.2.4 Excavation of the topsoil and the weathered portions of the Very Old Paralic Deposits should generally be possible with moderate to heavy effort using conventional, heavy-duty equipment during grading and trenching operations. We expect very heavy effort with possible refusal in localized areas for excavations into strongly cemented portions of the Very Old Paralic Deposits.

7.3 Grading

7.3.1 Grading should be performed in accordance with the recommendations provided in this report, the Recommended Grading Specifications contained in Appendix C and the City of Encinitas Grading Ordinance. Geocon Incorporated should observe the grading operations on a full-time basis and provide testing during the fill placement.

7.3.2 Prior to commencing grading, a preconstruction conference should be held at the site with the county inspector, developer, grading and underground contractors, civil engineer, and geotechnical engineer in attendance. Special soil handling and/or the grading plans can be discussed at that time.

7.3.3 Site preparation should begin with the removal of deleterious material, debris, and vegetation. The depth of vegetation removal should be such that material exposed in cut areas or soil to be used as fill is relatively free of organic matter. Material generated during stripping and/or site demolition should be exported from the site. Asphalt and concrete should not be mixed with the fill soil unless approved by the Geotechnical Engineer.

7.3.4 Abandoned foundations and buried utilities (if encountered) should be removed and the resultant depressions and/or trenches should be backfilled with properly compacted material as part of the remedial grading.

7.3.5 Topsoil and weathered formational materials within the limits of grading should be removed to expose dense formational materials. The actual depth of removal should be evaluated by the engineering geologist during grading operations.

7.3.6 We expect the planned structures will be supported on a shallow foundation system supported on properly compacted fill. The surficial fill soils should be removed to dense geologic unit and replaced with properly compacted fill within the areas of the proposed structures. In addition, to reduce the potential for differential settlement, the building pad area should be undercut in areas where formation is exposed within 3 feet of pad grade such that at least 3 feet of properly compacted fill exists below pad grade. The removals should extend at least 10 feet outside of the proposed foundation system, where possible.

7.3.7 We should observe the grading operations and the removal bottoms to check the exposure of the formational materials prior to the placement of compacted fill. Deeper excavations may be required if highly weathered formational materials are present at the base of the removals. Fill soil should not be placed until we observe the bottom excavations. Table 7.3.1 provides a summary of the grading recommendations.

**TABLE 7.3.1
SUMMARY OF GRADING RECOMMENDATIONS**

| Area | Removal Requirements |
|---|--|
| Topsoil and Weathered Very Old Paralic Deposits | Remove to Underlying, Dense Very Old Paralic Deposits |
| Very Old Paralic Deposits Within 3 Feet of Proposed Building Pad Elevations | Undercut 3 Feet Below Finish Grade |
| Very Old Paralic Deposits at Grade in Areas of Surface Improvements | Process Upper 1 to 2 Feet of Existing Materials |
| Lateral Grading Limits | 10 Feet Outside of Buildings/2 Feet Outside of Improvement Areas, Where Possible |
| Exposed Bottoms of Remedial Grading | Scarify Upper 12 Inches |

7.3.8 The bottom of the excavations should be sloped 1 percent to the adjacent street or deepest fill. Prior to fill soil being placed, the existing ground surface should be scarified, moisture conditioned as necessary, and compacted to a depth of at least 12 inches. Deeper removals may be required if saturated or loose fill soil is encountered. A representative of Geocon should be on-site during removals to evaluate the limits of the remedial grading.

7.3.9 Some areas of overly wet and saturated soil could be encountered due to the existing landscape and pavement areas. The saturated soil would require additional effort prior to placement of compacted fill or additional improvements. Stabilization of the soil would include scarifying and air-drying, removing and replacement with drier soil, use of stabilization fabric (e.g. Tensar TX7 or other approved fabric), or chemical treating (i.e. cement or lime treatment).

7.3.10 The contractor should be careful during the remedial grading operations to avoid a “pumping” condition at the base of the removals. Where recompaction of the excavated bottom will result in a “pumping” condition, the bottom of the excavation should be tracked with low ground pressure earthmoving equipment prior to placing fill. If needed to improve the stability of the excavation bottoms, reinforcing fabric or 2- to 3-inch crushed rock can be placed prior to placement of compacted fill.

- 7.3.11 The site should then be brought to final subgrade elevations with fill compacted in layers. In general, soil native to the site is suitable for use from a geotechnical engineering standpoint as fill if relatively free from vegetation, debris and other deleterious material. Layers of fill should be about 6 to 8 inches in loose thickness and no thicker than will allow for adequate bonding and compaction. Fill, including backfill and scarified ground surfaces, should be compacted to a dry density of at least 90 percent of the laboratory maximum dry density near to slightly above optimum moisture content in accordance with ASTM Test Procedure D 1557. Fill materials placed below optimum moisture content may require additional moisture conditioning prior to placing additional fill. The upper 12 inches of subgrade soil underlying pavement should be compacted to a dry density of at least 95 percent of the laboratory maximum dry density near to slightly above optimum moisture content shortly before paving operations.
- 7.3.12 Import fill (if necessary) should consist of the characteristics presented in Table 7.3.2. Geocon Incorporated should be notified of the import soil source and should perform laboratory testing of import soil prior to its arrival at the site to determine its suitability as fill material.

**TABLE 7.3.2
SUMMARY OF IMPORT FILL RECOMMENDATIONS**

| Soil Characteristic | Values |
|---------------------|--|
| Expansion Potential | “Very Low” to “Medium” (Expansion Index of 90 or less) |
| Particle Size | Maximum Dimension Less Than 3 Inches |
| | Generally Free of Debris |

- 7.3.13 The site should then be brought to final subgrade elevations with fill compacted in layers. In general, soil native to the site is suitable for use from a geotechnical engineering standpoint as fill if relatively free from vegetation, debris and other deleterious material. Table 7.3.3 provides a summary of the compaction recommendations. Layers of fill should be compacted to a dry density of at least 90 percent of the laboratory maximum dry density near to slightly above optimum moisture content in accordance with ASTM Test Procedure D 1557. Fill materials placed below optimum moisture content may require additional moisture conditioning prior to placing additional fill.

**TABLE 7.3.3
SUMMARY OF COMPACTION RECOMMENDATIONS**

| Soil Characteristic | Values |
|---|--|
| Loose Fill Thickness | About 6 to 8 Inches |
| | No Thicker Than Will Allow for Adequate Bonding and Compaction |
| Grading Compaction | 90 Percent |
| Utility Trench, Retaining Wall, Subgrade for Sidewalk and Curb/Gutter | 90 Percent |
| Pavement Subgrade, Base Materials | 95 Percent |
| Moisture Content | Near to Slightly Above Optimum |
| Expansion Potential (Upper 4 Feet) | “Very Low” to “Medium” (Expansion Index of 90 or less) |

- 7.3.14 Cut slope excavations should be observed during grading operations to check that soil and geologic conditions do not differ significantly from those expected.
- 7.3.15 The outer 15 feet (or a distance equal to the height of the slope, whichever is less) of fill slopes should be composed of properly compacted granular “soil” fill to reduce the potential for surficial sloughing. In general, soil with an expansion index of 90 or less or at least 35 percent sand-size particles should be acceptable as “soil” fill. Soil of questionable strength to satisfy surficial stability should be tested in the laboratory for acceptable drained shear strength. The use of cohesionless soil in the outer portion of fill slopes should be avoided. Fill slopes should be overbuilt 2 feet and cut back or be compacted by backrolling with a loaded sheepsfoot roller at vertical intervals not to exceed 4 feet and should be track-walked at the completion of each slope such that the fill is compacted to a dry density of at least 90 percent of the laboratory maximum dry density near to slightly above optimum moisture content to the face of the finished sloped.
- 7.3.16 Slopes should be landscaped with drought-tolerant vegetation having variable root depths and requiring minimal landscape irrigation. In addition, all slopes should be drained and properly maintained to reduce erosion.
- 7.3.17 Import fill (if necessary) should consist of the characteristics presented in Table 7.3.4. Geocon Incorporated should be notified of the import soil source and should perform laboratory testing of import soil prior to its arrival at the site to determine its suitability as fill material.

**TABLE 7.3.4
SUMMARY OF IMPORT FILL RECOMMENDATIONS**

| Soil Characteristic | Values |
|---------------------|--|
| Expansion Potential | “Very Low” to “Medium” (Expansion Index of 90 or less) |
| Particle Size | Maximum Dimension Less Than 3 Inches |
| | Generally Free of Debris |

7.3.18 Finished slopes should be landscaped with drought-tolerant vegetation having variable root depths and requiring minimal landscape irrigation. In addition, the slopes should be drained and properly maintained to reduce erosion.

7.4 Subdrains

7.4.1 With the exception of retaining wall drains, we do not expect the installation of other subdrains. We should be contacted to provide recommendations for wick drains, if proposed.

7.5 Temporary Excavations

7.5.1 The recommendations included herein are provided for stable excavations. It is the responsibility of the contractor and their competent person to ensure all excavations, temporary slopes and trenches are properly constructed and maintained in accordance with applicable OSHA guidelines in order to maintain safety and the stability of the excavations and adjacent improvements. These excavations should not be allowed to become saturated or to dry out. Surcharge loads should not be permitted to a distance equal to the height of the excavation from the top of the excavation. The top of the excavation should be a minimum of 15 feet from the edge of existing improvements. Excavations steeper than those recommended or closer than 15 feet from an existing surface improvement should be shored in accordance with applicable OSHA codes and regulations.

7.5.2 The stability of the excavations is dependent on the design and construction of the shoring system and site conditions. Therefore, Geocon Incorporated cannot be responsible for site safety and the stability of the proposed excavations.

7.6 Seismic Design Criteria – 2019 California Building Code

7.6.1 Table 7.6.1 summarizes site-specific design criteria obtained from the 2019 California Building Code (CBC; Based on the 2018 International Building Code [IBC] and ASCE 7-16), Chapter 16 Structural Design, Section 1613 Earthquake Loads. We used the computer program *U.S. Seismic Design Maps*, provided by the Structural Engineers Association (SEA) to calculate the seismic design parameters. The short spectral response uses a period of 0.2

second. We evaluated the Site Class based on the discussion in Section 1613.2.2 of the 2019 CBC and Table 20.3-1 of ASCE 7-16. The values presented herein are for the risk-targeted maximum considered earthquake (MCE_R). Sites designated as Site Class D, E and F may require additional analyses if requested by the project structural engineer and client.

**TABLE 7.6.1
2019 CBC SEISMIC DESIGN PARAMETERS**

| Parameter | Value | 2019 CBC Reference |
|--|---------|------------------------------|
| Site Class | C | Section 1613.2.2 |
| MCE_R Ground Motion Spectral Response Acceleration – Class B (short), S_s | 1.114g | Figure 1613.2.1(1) |
| MCE_R Ground Motion Spectral Response Acceleration – Class B (1 sec), S_1 | 0.398g | Figure 1613.2.1(2) |
| Site Coefficient, F_A | 1.200 | Table 1613.2.3(1) |
| Site Coefficient, F_V | 1.500* | Table 1613.2.3(2) |
| Site Class Modified MCE_R Spectral Response Acceleration (short), S_{MS} | 1.336g | Section 1613.2.3 (Eqn 16-36) |
| Site Class Modified MCE_R Spectral Response Acceleration – (1 sec), S_{M1} | 0.598g* | Section 1613.2.3 (Eqn 16-37) |
| 5% Damped Design Spectral Response Acceleration (short), S_{DS} | 0.891g | Section 1613.2.4 (Eqn 16-38) |
| 5% Damped Design Spectral Response Acceleration (1 sec), S_{D1} | 0.398* | Section 1613.2.4 (Eqn 16-39) |

*Using the code-based values presented in this table, in lieu of a performing a ground motion hazard analysis, requires the exceptions outlined in ASCE 7-16 Section 11.4.8 be followed by the project structural engineer. Per Section 11.4.8 of ASCE/SEI 7-16, a ground motion hazard analysis should be performed for projects for Site Class “E” sites with S_s greater than or equal to 1.0g and for Site Class “D” and “E” sites with S_1 greater than 0.2g. Section 11.4.8 also provides exceptions which indicates that the ground motion hazard analysis may be waived provided the exceptions are followed.

7.6.2 Table 7.6.2 presents the mapped maximum considered geometric mean (MCE_G) seismic design parameters for projects located in Seismic Design Categories of D through F in accordance with ASCE 7-16.

**TABLE 7.6.2
ASCE 7-16 PEAK GROUND ACCELERATION**

| Parameter | Value | ASCE 7-16 Reference |
|---|--------|-----------------------------|
| Mapped MCE_G Peak Ground Acceleration, PGA | 0.495g | Figure 22-7 |
| Site Coefficient, F_{PGA} | 1.2 | Table 11.8-1 |
| Site Class Modified MCE_G Peak Ground Acceleration, PGA_M | 0.594g | Section 11.8.3 (Eqn 11.8-1) |

7.6.3 Conformance to the criteria in Tables 7.6.1 and 7.6.2 for seismic design does not constitute any kind of guarantee or assurance that significant structural damage or ground failure will not occur in the event of a large earthquake. The primary goal of seismic design is to protect life, not to avoid all damage, since such design may be economically prohibitive.

7.6.4 The project structural engineer and architect should evaluate the appropriate Risk Category and Seismic Design Category for the planned structures. The values presented herein assume a Risk Category of II and resulting in a Seismic Design Category D. Table 7.6.3 presents a summary of the risk categories in accordance with ASCE 7-16.

**TABLE 7.6.3
ASCE 7-16 RISK CATEGORIES**

| Risk Category | Building Use | Examples |
|---------------|---|--|
| I | Low risk to Human Life at Failure | Barn, Storage Shelter |
| II | Nominal Risk to Human Life at Failure (Buildings Not Designated as I, III or IV) | Residential, Commercial and Industrial Buildings |
| III | Substantial Risk to Human Life at Failure | Theaters, Lecture Halls, Dining Halls, Schools, Prisons, Small Healthcare Facilities, Infrastructure Plants, Storage for Explosives/Toxins |
| IV | Essential Facilities | Hazardous Material Facilities, Hospitals, Fire and Rescue, Emergency Shelters, Police Stations, Power Stations, Aviation Control Facilities, National Defense, Water Storage |

7.7 Preliminary Foundation and Concrete Slabs-On-Grade Recommendations

7.7.1 The foundation recommendations herein are for the proposed residential structures. The foundation recommendations have been separated into three categories based on the maximum and differential fill thickness and expansion index. The foundation category criteria are presented in Table 7.7.1. Based on review of the laboratory test results performed during our investigation, we expect majority of the soil encountered on site is planned to possess a “very low” expansion potential (expansion index of 20 or less). Recommended foundation categories for the subject building pads will be provided after fine grading is completed and we re-evaluate the expansion index of the fill material in the upper 3 to 4 feet during the regrading operations.

**TABLE 7.7.1
FOUNDATION CATEGORY CRITERIA**

| Foundation Category | Maximum Fill Thickness, T (feet) | Differential Fill Thickness, D (feet) | Expansion Index (EI) |
|---------------------|----------------------------------|---------------------------------------|----------------------|
| I | $T < 20$ | -- | $EI \leq 50$ |
| II | $20 \leq T < 50$ | $10 \leq D < 20$ | $50 < EI \leq 90$ |
| III | $T \geq 50$ | $D \geq 20$ | $90 < EI \leq 130$ |

7.7.2 Table 7.7.2 presents minimum foundation and interior concrete slab design criteria for conventional foundation systems. The grading of building pads should be such that the upper 3 feet of finish grade soils should have an expansion index of 90 or less.

**TABLE 7.7.2
CONVENTIONAL FOUNDATION RECOMMENDATIONS BY CATEGORY**

| Foundation Category | Minimum Footing Embedment Depth (inches) | Continuous Footing Reinforcement | Interior Slab Reinforcement |
|---------------------|--|---|--|
| I | 12 | Two No. 4 bars, one top and one bottom | 6 x 6 - 10/10 welded wire mesh at slab mid-point |
| II | 18 | Four No. 4 bars, two top and two bottom | No. 3 bars at 24 inches on center, both directions |
| III | 24 | Four No. 5 bars, two top and two bottom | No. 3 bars at 18 inches on center, both directions |

7.7.3 The embedment depths presented in Table 7.7.2 should be measured from the lowest adjacent pad grade for both interior and exterior footing. The foundations should be embedded in accordance with the recommendations herein and the Wall/Column Footing Dimension Detail. The embedment depths should be measured from the lowest adjacent pad grade for both interior and exterior footings. Footings should be deepened such that the bottom outside edge of the footing is at least 7 feet horizontally from the face of the slope (unless designed with a post-tensioned foundation system as discussed herein).

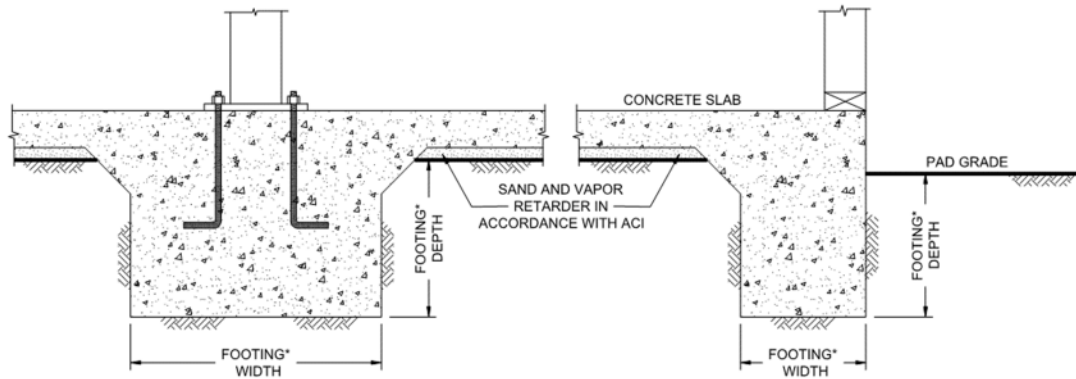

Wall/Column Footing Dimension Detail

- 7.7.4 The bearing capacity values presented herein are for dead plus live loads and may be increased by one-third when considering transient loads due to wind or seismic forces.
- 7.7.5 The concrete slab-on-grade should be a minimum of 4 inches thick for Foundation Categories I and II and 5 inches thick for Foundation Category III.
- 7.7.6 Slabs that may receive moisture-sensitive floor coverings or may be used to store moisture-sensitive materials should be underlain by a vapor retarder. The vapor retarder design should be consistent with the guidelines presented in the American Concrete Institute's (*ACI Guide for Concrete Slabs that Receive Moisture-Sensitive Flooring Materials* (ACI 302.2R-06)). In addition, the membrane should be installed in accordance with manufacturer's recommendations and ASTM requirements and installed in a manner that prevents puncture. The vapor retarder used should be specified by the project architect or developer based on the type of floor covering that will be installed and if the structure will possess a humidity-controlled environment.
- 7.7.7 Placement of 3 inches and 4 inches of sand is common practice in Southern California for 5-inch and 4-inch thick slabs, respectively. The foundation engineer should provide appropriate concrete mix design criteria and curing measures that may be utilized to assure proper curing of the slab to reduce the potential for rapid moisture loss and subsequent cracking and/or slab curl. We suggest that the foundation engineer present concrete mix design and proper curing methods on the foundation plans. It is critical that the foundation contractor understands and follows the recommendations presented on the foundation plans.
- 7.7.8 As an alternative to the conventional foundation recommendations, consideration should be given to the use of post-tensioned concrete slab and foundation systems for the support of the proposed structures. If a post-tensioned system is being used, the proposed buildings would be designated with a Foundation Category once grading is completed. The post-tensioned

systems should be designed by a structural engineer experienced in post-tensioned slab design and design criteria of the Post-Tensioning Institute (PTI) DC 10.5-12 *Standard Requirements for Design and Analysis of Shallow Post-Tensioned Concrete Foundations on Expansive Soils* or *WRI/CRSI Design of Slab-on-Ground Foundations*, as required by the 2019 California Building Code (CBC Section 1808.6.2). Although this procedure was developed for expansive soil conditions, it can also be used to reduce the potential for foundation distress due to differential fill settlement. The post-tensioned design should incorporate the geotechnical parameters presented in Table 7.7.3 for the particular Foundation Category designated. The parameters presented in Table 7.7.3 are based on the guidelines presented in the PTI DC 10.5 design manual.

**TABLE 7.7.3
POST-TENSIONED FOUNDATION SYSTEM DESIGN PARAMETERS**

| Post-Tensioning Institute (PTI) DC10.5 Design Parameters | Foundation Category | | |
|---|---------------------|------|------|
| | I | II | III |
| Thornthwaite Index | -20 | -20 | -20 |
| Equilibrium Suction | 3.9 | 3.9 | 3.9 |
| Edge Lift Moisture Variation Distance, e_M (Feet) | 5.3 | 5.1 | 4.9 |
| Edge Lift, y_M (Inches) | 0.61 | 1.10 | 1.58 |
| Center Lift Moisture Variation Distance, e_M (Feet) | 9.0 | 9.0 | 9.0 |
| Center Lift, y_M (Inches) | 0.30 | 0.47 | 0.66 |

- 7.7.9 We will provide the Foundation Category for each building to design the post-tensioned foundations once grading and additional laboratory testing is completed.
- 7.7.10 The foundations for the post-tensioned slabs should be embedded in accordance with the recommendations of the structural engineer. If a post-tensioned mat foundation system is planned, the slab should possess a thickened edge with a minimum width of 12 inches and extend below the clean sand or crushed rock layer.
- 7.7.11 If the structural engineer proposes a post-tensioned foundation design method other than PTI, DC 10.5:
- The deflection criteria presented in Table 7.7.3 are still applicable.
 - Interior stiffener beams should be used for Foundation Categories II and III.
 - The width of the perimeter foundations should be at least 12 inches.
 - The perimeter footing embedment depths should be at least 12 inches, 18 inches and 24 inches for foundation categories I, II, and III, respectively. The embedment depths should be measured from the lowest adjacent pad grade.

- 7.7.12 Our experience indicates post-tensioned slabs may be susceptible to excessive edge lift from tensioning, regardless of the underlying soil conditions. Placing reinforcing steel at the bottom of the perimeter footings and the interior stiffener beams may mitigate this potential. The structural engineer should design the foundation system to reduce the potential of edge lift occurring for the proposed structures.
- 7.7.13 During the construction of the post-tension foundation system, the concrete should be placed monolithically. Under no circumstances should cold joints form between the footings/grade beams and the slab during the construction of the post-tension foundation system unless designed by the structural engineer.
- 7.7.14 Category I, II, or III foundations may be designed for an allowable soil bearing pressure of 2,000 pounds per square foot (psf) (dead plus live load). This bearing pressure may be increased by one-third for transient loads due to wind or seismic forces. The estimated maximum total and differential settlement for the planned structures due to foundation loads is 1 inch and ½ inch, respectively.
- 7.7.15 Isolated footings outside of the slab area, if present, should have the minimum embedment depth and width recommended for conventional foundations for a particular Foundation Category. The use of isolated footings, which are located beyond the perimeter of the building and support structural elements connected to the building, are not recommended for Category III. Where this condition cannot be avoided, the isolated footings should be connected to the building foundation system with grade beams. In addition, consideration should be given to connecting patio slabs, which exceed 5 feet in width, to the building foundation to reduce the potential for future separation to occur.
- 7.7.16 Interior stiffening beams should be incorporated into the design of the foundation system in accordance with the PTI design procedures.
- 7.7.17 Special subgrade presaturation is not deemed necessary prior to placing concrete; however, the exposed foundation and slab subgrade soil should be moisture conditioned, as necessary, to maintain a moist condition as would be expected in any such concrete placement.
- 7.7.18 Where buildings or other improvements are planned near the top of a slope 3:1 (horizontal:vertical) or steeper, special foundation and/or design considerations are recommended due to the tendency for lateral soil movement to occur.
- For fill slopes less than 20 feet high or cut slopes regardless of height, footings should be deepened such that the bottom outside edge of the footing is at least 7 feet horizontally from the face of the slope.

- When located next to a descending 3:1 (horizontal:vertical) fill slope or steeper, the foundations should be extended to a depth where the minimum horizontal distance is equal to $H/3$ (where H equals the vertical distance from the top of the fill slope to the base of the fill soil) with a minimum of 7 feet but need not exceed 40 feet. The horizontal distance is measured from the outer, deepest edge of the footing to the face of the slope. A post-tensioned slab and foundation system or mat foundation system can be used to reduce the potential for distress in the structures associated with strain softening and lateral fill extension. Specific design parameters or recommendations for either of these alternatives can be provided once the building location and fill slope geometry have been determined.
- If swimming pools are planned, Geocon Incorporated should be contacted for a review of specific site conditions.
- Swimming pools located within 7 feet of the top of cut or fill slopes are not recommended. Where such a condition cannot be avoided, the portion of the swimming pool wall within 7 feet of the slope face be designed assuming that the adjacent soil provides no lateral support. This recommendation applies to fill slopes up to 30 feet in height, and cut slopes regardless of height. For swimming pools located near the top of fill slopes greater than 30 feet in height, additional recommendations may be required and Geocon Incorporated should be contacted for a review of specific site conditions.
- Although other improvements, which are relatively rigid or brittle, such as concrete flatwork or masonry walls, may experience some distress if located near the top of a slope, it is generally not economical to mitigate this potential. It may be possible, however, to incorporate design measures which would permit some lateral soil movement without causing extensive distress. Geocon Incorporated should be consulted for specific recommendations.

7.7.19 The recommendations of this report are intended to reduce the potential for cracking of slabs and foundations due to expansive soil (if present), differential settlement of fill soil with varying thicknesses. However, even with the incorporation of the recommendations presented herein, foundations, stucco walls, and slabs-on-grade placed on such conditions may still exhibit some cracking due to soil movement and/or shrinkage. The occurrence of concrete shrinkage cracks is independent of the supporting soil characteristics. Their occurrence may be reduced by limiting the slump of the concrete, proper concrete placement and curing, and by the placement of crack control joints at periodic intervals, in particular, where re-entrant slab corners occur.

7.7.20 Concrete slabs should be provided with adequate crack-control joints, construction joints and/or expansion joints to reduce unsightly shrinkage cracking. The design of joints should consider criteria of the American Concrete Institute when establishing crack-control spacing. Additional steel reinforcing, concrete admixtures and/or closer crack control joint spacing should be considered where concrete-exposed finished floors are planned.

7.7.21 Geocon Incorporated should be consulted to provide additional design parameters as required by the structural engineer.

7.7.22 We should observe the foundation excavations prior to the placement of reinforcing steel to check that the exposed soil conditions are similar to those expected and that they have been extended to the appropriate bearing strata. If unexpected soil conditions are encountered, foundation modifications may be required.

7.8 Exterior Concrete Flatwork

7.8.1 Exterior concrete flatwork not subject to vehicular traffic should be constructed in accordance with the recommendations presented in Table 7.8. The recommended steel reinforcement would help reduce the potential for cracking.

**TABLE 7.8
MINIMUM CONCRETE FLATWORK RECOMMENDATIONS**

| Expansion Index, EI | Minimum Steel Reinforcement* Options | Minimum Thickness |
|---------------------|---|-------------------|
| EI ≤ 90 | 6x6-W2.9/W2.9 (6x6-6/6) welded wire mesh | 4 Inches |
| | No. 3 Bars 18 inches on center, Both Directions | |

* In excess of 8 feet square.

7.8.2 The subgrade soil should be properly moisturized and compacted prior to the placement of steel and concrete. The subgrade soil should be compacted to a dry density of at least 90 percent of the laboratory maximum dry density near to slightly above optimum moisture content in accordance with ASTM D 1557.

7.8.3 Even with the incorporation of the recommendations of this report, the exterior concrete flatwork has a potential to experience some uplift due to expansive soil beneath grade. The steel reinforcement should overlap continuously in flatwork to reduce the potential for vertical offsets within flatwork. Additionally, flatwork should be structurally connected to the curbs, where possible, to reduce the potential for offsets between the curbs and the flatwork.

7.8.4 Concrete flatwork should be provided with crack control joints to reduce and/or control shrinkage cracking. Crack control spacing should be determined by the project structural engineer based upon the slab thickness and intended usage. Criteria of the American Concrete Institute (ACI) should be taken into consideration when establishing crack control spacing. Subgrade soil for exterior slabs not subjected to vehicle loads should be compacted in accordance with criteria presented in the grading section prior to concrete placement.

Subgrade soil should be properly compacted and the moisture content of subgrade soil should be verified prior to placing concrete. Base materials will not be required below concrete improvements.

7.8.5 Where exterior flatwork abuts the structure at entrant or exit points, the exterior slab should be dowelled into the structure’s foundation stemwall. This recommendation is intended to reduce the potential for differential elevations that could result from differential settlement or minor heave of the flatwork. Dowelling details should be designed by the project structural engineer.

7.9 Retaining Walls

7.9.1 Retaining walls should be designed using the values presented in Table 7.9.1. Soil with an expansion index (EI) of greater than 90 should not be used as backfill material behind retaining walls.

**TABLE 7.9.1
RETAINING WALL DESIGN RECOMMENDATIONS**

| Parameter | Value |
|---|--------------|
| Active Soil Pressure, A (Fluid Density, Level Backfill) | 35 pcf |
| Active Soil Pressure, A (Fluid Density, 2:1 Sloping Backfill) | 50 pcf |
| Seismic Pressure, S | 15H psf |
| At-Rest/Restrained Walls Additional Uniform Pressure (0 to 8 Feet High) | 7H psf |
| At-Rest/Restrained Walls Additional Uniform Pressure (8+ Feet High) | 13H psf |
| Expected Expansion Index for the Subject Property | EI \leq 90 |

H equals the height of the retaining portion of the wall.

7.9.2 The project retaining walls should be designed as shown in the Retaining Wall Loading Diagram.

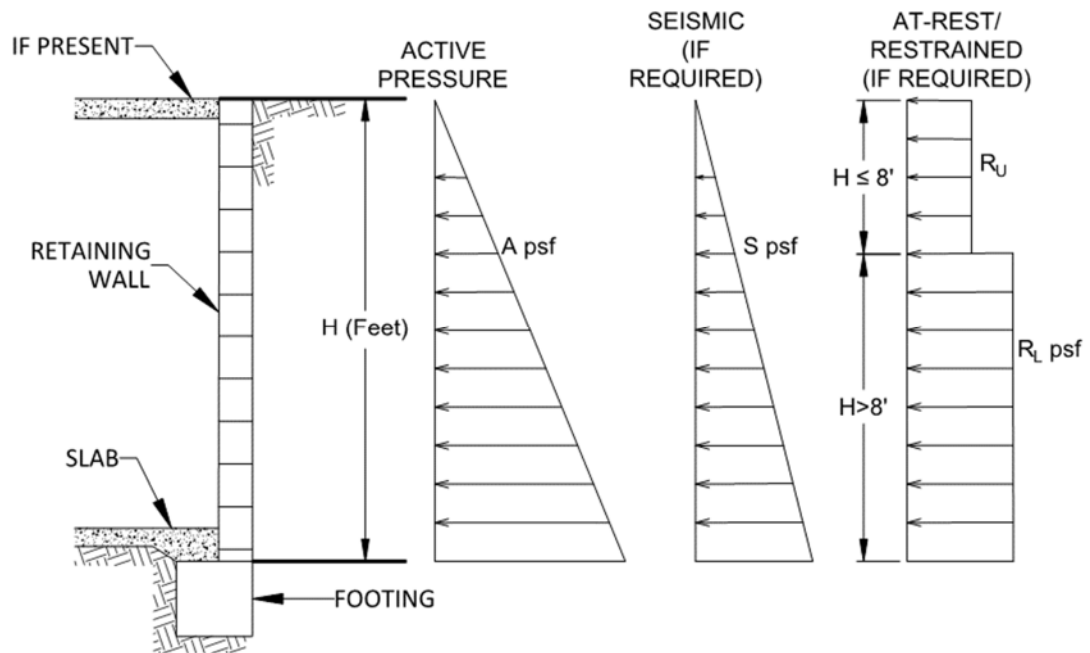

Retaining Wall Loading Diagram

- 7.9.3 Unrestrained walls are those that are allowed to rotate more than $0.001H$ (where H equals the height of the retaining portion of the wall) at the top of the wall. Where walls are restrained from movement at the top (at-rest condition), an additional uniform pressure should be applied to the wall. For retaining walls subject to vehicular loads within a horizontal distance equal to two-thirds the wall height, a surcharge equivalent to 2 feet of fill soil should be added.
- 7.9.4 The structural engineer should determine the Seismic Design Category for the project in accordance with Section 1613.3.5 of the 2019 CBC or Section 11.6 of ASCE 7-10. For structures assigned to Seismic Design Category of D, E, or F, retaining walls that support more than 6 feet of backfill should be designed with seismic lateral pressure in accordance with Section 1803.5.12 of the 2019 CBC. The seismic load is dependent on the retained height where H is the height of the wall, in feet, and the calculated loads result in pounds per square foot (psf) exerted at the base of the wall and zero at the top of the wall.
- 7.9.5 Retaining walls should be designed to ensure stability against overturning sliding, and excessive foundation pressure. Where a keyway is extended below the wall base with the intent to engage passive pressure and enhance sliding stability, it is not necessary to consider active pressure on the keyway.
- 7.9.6 Drainage openings through the base of the wall (weep holes) should not be used where the seepage could be a nuisance or otherwise adversely affect the property adjacent to the base of the wall. The recommendations herein assume a properly compacted granular (EI of 90 or

less) free-draining backfill material with no hydrostatic forces or imposed surcharge load. The retaining wall should be properly drained as shown in the Typical Retaining Wall Drainage Detail. If conditions different than those described are expected, or if specific drainage details are desired, Geocon Incorporated should be contacted for additional recommendations.

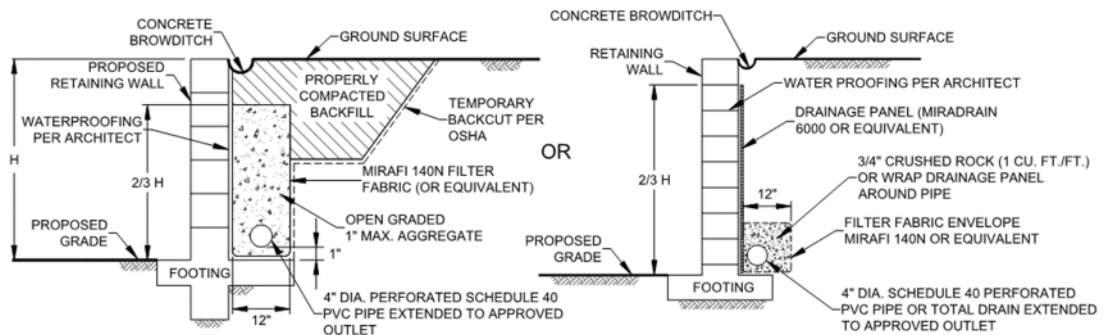

Typical Retaining Wall Drainage Detail

7.9.7 The retaining walls may be designed using either the active and restrained (at-rest) loading condition or the active and seismic loading condition as suggested by the structural engineer. Typically, it appears the design of the restrained condition for retaining wall loading may be adequate for the seismic design of the retaining walls. However, the active earth pressure combined with the seismic design load should be reviewed and also considered in the design of the retaining walls.

7.9.8 In general, wall foundations should be designed in accordance with Table 7.9.2. The proximity of the foundation to the top of a slope steeper than 3:1 could impact the allowable soil bearing pressure. Therefore, retaining wall foundations should be deepened such that the bottom outside edge of the footing is at least 7 feet horizontally from the face of the slope.

**TABLE 7.9.2
SUMMARY OF RETAINING WALL FOUNDATION RECOMMENDATIONS**

| Parameter | Value |
|---|---------------------------|
| Minimum Retaining Wall Foundation Width | 12 Inches |
| Minimum Retaining Wall Foundation Depth | 12 Inches |
| Minimum Steel Reinforcement | Per Structural Engineer |
| Allowable Bearing Capacity | 2,000 psf |
| Bearing Capacity Increase | 500 psf per Foot of Depth |
| | 300 psf per Foot of Width |
| Maximum Allowable Bearing Capacity | 3,500 psf |
| Estimated Total Settlement | 1 Inch |
| Estimated Differential Settlement | ½ Inch in 40 Feet |

- 7.9.9 The recommendations presented herein are generally applicable to the design of rigid concrete or masonry retaining walls. In the event that other types of walls (such as mechanically stabilized earth [MSE] walls, soil nail walls, or soldier pile walls) are planned, Geocon Incorporated should be consulted for additional recommendations.
- 7.9.10 Unrestrained walls will move laterally when backfilled and loading is applied. The amount of lateral deflection is dependent on the wall height, the type of soil used for backfill, and loads acting on the wall. The retaining walls and improvements above the retaining walls should be designed to incorporate an appropriate amount of lateral deflection as determined by the structural engineer.
- 7.9.11 Soil contemplated for use as retaining wall backfill, including import materials, should be identified in the field prior to backfill. At that time, Geocon Incorporated should obtain samples for laboratory testing to evaluate its suitability. Modified lateral earth pressures may be necessary if the backfill soil does not meet the required expansion index or shear strength. City or regional standard wall designs, if used, are based on a specific active lateral earth pressure and/or soil friction angle. In this regard, on-site soil to be used as backfill may or may not meet the values for standard wall designs. Geocon Incorporated should be consulted to assess the suitability of the on-site soil for use as wall backfill if standard wall designs will be used.

7.10 Lateral Loading

- 7.10.1 Table 7.10 should be used to help design the proposed structures and improvements to resist lateral loads for the design of footings or shear keys. The allowable passive pressure assumes a horizontal surface extending at least 5 feet, or three times the surface generating the passive pressure, whichever is greater. The upper 12 inches of material in areas not protected by floor slabs or pavement should not be included in design for passive resistance.

**TABLE 7.10
SUMMARY OF LATERAL LOAD DESIGN RECOMMENDATIONS**

| Parameter | Value |
|---|--------------|
| Passive Pressure Fluid Density | 350 pcf |
| Coefficient of Friction (Concrete and Soil) | 0.35 |
| Coefficient of Friction (Along Vapor Barrier) | 0.2 to 0.25* |

* Per manufacturer's recommendations.

7.10.2 The passive and frictional resistant loads can be combined for design purposes. The lateral passive pressures may be increased by one-third when considering transient loads due to wind or seismic forces.

7.11 Preliminary Pavement Recommendations

7.11.1 We calculated the flexible pavement sections in general conformance with the *Caltrans Method of Flexible Pavement Design* (Highway Design Manual, Section 608.4) using an estimated Traffic Index (TI) of 5.0, 5.5, 6.0, and 7.0 for parking stalls, driveways, medium truck traffic areas, and heavy truck traffic areas, respectively. The project civil engineer and owner should review the pavement designations to determine appropriate locations for pavement thickness. The final pavement sections for the roadways should be based on the R-Value of the subgrade soil encountered at final subgrade elevation. Based on laboratory testing during our field investigation an R-Value of 27 and an assumed 78 R-Value for the subgrade soil and base materials, respectively, for the purposes of this preliminary analysis. Table 7.11.1 presents the preliminary flexible pavement sections.

**TABLE 7.11.1
PRELIMINARY FLEXIBLE PAVEMENT SECTION**

| Location | Assumed Traffic Index | Assumed Subgrade R-Value | Asphalt Concrete (inches) | Class 2 Aggregate Base (inches) |
|--|-----------------------|--------------------------|---------------------------|---------------------------------|
| Parking stalls for automobiles and light-duty vehicles | 5.0 | 27 | 3 | 6 |
| Driveways for automobiles and light-duty vehicles | 5.5 | 27 | 3 | 8 |
| Medium truck traffic areas | 6.0 | 27 | 3.5 | 9 |
| Driveways for heavy truck traffic | 7.0 | 27 | 4 | 10 |

7.11.2 Prior to placing base materials, the upper 12 inches of the subgrade soil should be scarified, moisture conditioned as necessary, and recompact to a dry density of at least 95 percent of the laboratory maximum dry density near to slightly above optimum moisture content as determined by ASTM D 1557. Similarly, the base material should be compacted to a dry density of at least 95 percent of the laboratory maximum dry density near to slightly above optimum moisture content. Asphalt concrete should be compacted to a density of at least 95 percent of the laboratory Hveem density in accordance with ASTM D 2726.

7.11.3 A rigid Portland cement concrete (PCC) pavement section should be placed in roadway aprons and cross gutters. We calculated the rigid pavement section in general conformance with the procedure recommended by the American Concrete Institute report ACI 330-21 *Commercial Concrete Parking Lots and Site Paving Design and Construction – Guide*. Table 7.11.2

provides the traffic categories and design parameters used for the calculations for 20-year design life.

**TABLE 7.11.2
TRAFFIC CATEGORIES**

| Traffic Category | Description | Reliability (%) | Slabs Cracked at End of Design Life (%) |
|------------------|------------------------------------|-----------------|---|
| A | Car Parking Areas and Access Lanes | 60 | 15 |
| B | Entrance and Truck Service Lanes | 60 | 15 |
| E | Garbage or Fire Truck Lane | 75 | 15 |

7.11.4 We used the parameters presented in Table 7.11.3 to calculate the pavement design sections. We should be contacted to provide updated design sections, if necessary.

**TABLE 7.11.3
RIGID PAVEMENT DESIGN PARAMETERS**

| Design Parameter | Design Value |
|--|---------------|
| Modulus of Subgrade Reaction, k | 100 pci |
| Modulus of Rupture for Concrete, M_R | 500 psi |
| Concrete Compressive Strength | 3,000 psi |
| Concrete Modulus of Elasticity, E | 3,150,000 psi |

7.11.5 Based on the criteria presented herein, the PCC pavement sections should have a minimum thickness as presented in Table 7.11.4.

**TABLE 7.11.4
RIGID VEHICULAR PAVEMENT RECOMMENDATIONS**

| Traffic Category | Trucks Per Day | Portland Cement Concrete, T (Inches) |
|--|----------------|--------------------------------------|
| A = Car Parking Areas and Access Lanes | 10 | 5½ |
| B = Entrance and Truck Service Lanes | 10 | 6 |
| E = Garbage or Fire Truck Lanes | 5 | 6½ |

7.11.6 The PCC vehicular pavement should be placed over subgrade soil that is compacted to a dry density of at least 95 percent of the laboratory maximum dry density near to slightly above

optimum moisture content. The garbage truck pad should be large enough such that all wheels are on the concrete pad during the loading operations.

- 7.11.7 Adequate joint spacing should be incorporated into the design and construction of the rigid pavement in accordance with Table 7.11.5.

**TABLE 7.11.5
MAXIMUM JOINT SPACING**

| Pavement Thickness, T (Inches) | Maximum Joint Spacing (Feet) |
|--------------------------------|------------------------------|
| $4 < T < 5$ | 10 |
| $5 \leq T < 6$ | 12.5 |
| $6 \leq T$ | 15 |

- 7.11.8 The rigid pavement should also be designed and constructed incorporating the parameters presented in Table 7.11.6.

**TABLE 7.11.6
ADDITIONAL RIGID PAVEMENT RECOMMENDATIONS**

| Subject | Value |
|---------------------------|---|
| Thickened Edge | 1.2 Times Slab Thickness Adjacent to Structures |
| | 1.5 Times Slab Thickness Adjacent to Soil |
| | Minimum Increase of 2 Inches |
| | 4 Feet Wide |
| Crack Control Joint Depth | Early Entry Sawn = $T/6$ to $T/5$, 1.25 Inch Minimum |
| | Conventional (Tooled or Conventional Sawing) = $T/4$ to $T/3$ |
| Crack Control Joint Width | $1/4$ -Inch for Sealed Joints and Per Sealer Manufacturer's Recommendations |
| | $1/16$ - to $1/4$ -Inch is Common for Unsealed Joints |

- 7.11.9 Reinforcing steel will not be necessary within the concrete for geotechnical purposes with the possible exception of dowels at construction joints as discussed herein.

- 7.11.10 To control the location and spread of concrete shrinkage cracks, crack-control joints (weakened plane joints) should be included in the design of the concrete pavement slab. Crack-control joints should be sealed with an appropriate sealant to prevent the migration of water through the control joint to the subgrade materials. The depth of the crack-control joints should be in accordance with the referenced ACI guide.

- 7.11.11 To provide load transfer between adjacent pavement slab sections, a butt-type construction joint should be constructed. The butt-type joint should be thickened by at least 20 percent at the edge and taper back at least 4 feet from the face of the slab.
- 7.11.12 Concrete curb/gutter should be placed on soil subgrade compacted to a dry density of at least 90 percent of the laboratory maximum dry density near to slightly above optimum moisture content. Cross-gutters that receive vehicular traffic should be placed on subgrade soil compacted to a dry density of at least 95 percent of the laboratory maximum dry density near to slightly above optimum moisture content. Base materials should not be placed below the curb/gutter, or cross-gutters so water is not able to migrate from the adjacent parkways to the pavement sections. Where flatwork is located directly adjacent to the curb/gutter, the concrete flatwork should be structurally connected to the curbs to help reduce the potential for offsets between the curbs and the flatwork.

7.12 Site Drainage and Moisture Protection

- 7.12.1 Adequate site drainage is critical to reduce the potential for differential soil movement, erosion and subsurface seepage. Under no circumstances should water be allowed to pond adjacent to footings. The site should be graded and maintained such that surface drainage is directed away from structures in accordance with 2019 CBC 1804.4 or other applicable standards. In addition, surface drainage should be directed away from the top of slopes into swales or other controlled drainage devices. Roof and pavement drainage should be directed into conduits that carry runoff away from the proposed structure.
- 7.12.2 Underground utilities should be leak free. Utility and irrigation lines should be checked periodically for leaks, and detected leaks should be repaired promptly. Detrimental soil movement could occur if water is allowed to infiltrate the soil for prolonged periods of time.
- 7.12.3 Landscaping planters adjacent to paved areas are not recommended due to the potential for surface or irrigation water to infiltrate the pavement's subgrade and base course. Area drains to collect excess irrigation water and transmit it to drainage structures or impervious above-grade planter boxes can be used. In addition, where landscaping is planned adjacent to the pavement, construction of a cutoff wall along the edge of the pavement that extends at least 6 inches below the bottom of the base material should be considered.

7.13 Grading and Foundation Plan Review

7.13.1 Geocon Incorporated should review the grading and building foundation plans for the project prior to final design submittal to evaluate if additional analyses and/or recommendations are required.

7.14 Testing and Observation Services During Construction

7.14.1 Geocon Incorporated should provide geotechnical testing and observation services during the grading operations, foundation construction, utility installation, retaining wall backfill and pavement installation. Table 7.14 presents the typical geotechnical observations we would expect for the proposed improvements.

**TABLE 7.14
EXPECTED GEOTECHNICAL TESTING AND OBSERVATION SERVICES**

| Construction Phase | Observations | Expected Time Frame |
|--|---|------------------------------|
| Grading | Base of Removal | Part Time During Removals |
| | Geologic Logging | Part Time to Full Time |
| | Fill Placement and Soil Compaction Operations | Full Time |
| Foundations | Foundation Excavation Observations | Part Time |
| Utility Backfill | Fill Placement and Soil Compaction Operations | Part Time to Full Time |
| Retaining Wall Backfill | Fill Placement and Soil Compaction Operations | Part Time to Full Time |
| Subgrade for Sidewalks, Curb/Gutter and Pavement | Soil Compaction Operations | Part Time |
| Pavement Construction | Base Placement and Compaction | Part Time |
| | Asphalt Concrete Placement and Compaction | Full Time |

LIMITATIONS AND UNIFORMITY OF CONDITIONS

1. The firm that performed the geotechnical investigation for the project should be retained to provide testing and observation services during construction to provide continuity of geotechnical interpretation and to check that the recommendations presented for geotechnical aspects of site development are incorporated during site grading, construction of improvements, and excavation of foundations. If another geotechnical firm is selected to perform the testing and observation services during construction operations, that firm should prepare a letter indicating their intent to assume the responsibilities of project geotechnical engineer of record. A copy of the letter should be provided to the regulatory agency for their records. In addition, that firm should provide revised recommendations concerning the geotechnical aspects of the proposed development, or a written acknowledgement of their concurrence with the recommendations presented in our report. They should also perform additional analyses deemed necessary to assume the role of Geotechnical Engineer of Record.
2. The recommendations of this report pertain only to the site investigated and are based on the assumption that the soil conditions do not deviate from those disclosed in the investigation. If any variations or undesirable conditions are encountered during construction, or if the proposed construction will differ from that anticipated herein, Geocon Incorporated should be notified so that supplemental recommendations can be given. The evaluation or identification of the potential presence of hazardous or corrosive materials was not part of the scope of services provided by Geocon Incorporated.
3. This report is issued with the understanding that it is the responsibility of the owner or their representative to ensure that the information and recommendations contained herein are brought to the attention of the architect and engineer for the project and incorporated into the plans, and the necessary steps are taken to see that the contractor and subcontractors carry out such recommendations in the field.
4. The findings of this report are valid as of the present date. However, changes in the conditions of a property can occur with the passage of time, whether they be due to natural processes or the works of man on this or adjacent properties. In addition, changes in applicable or appropriate standards may occur, whether they result from legislation or the broadening of knowledge. Accordingly, the findings of this report may be invalidated wholly or partially by changes outside our control. Therefore, this report is subject to review and should not be relied upon after a period of three years.

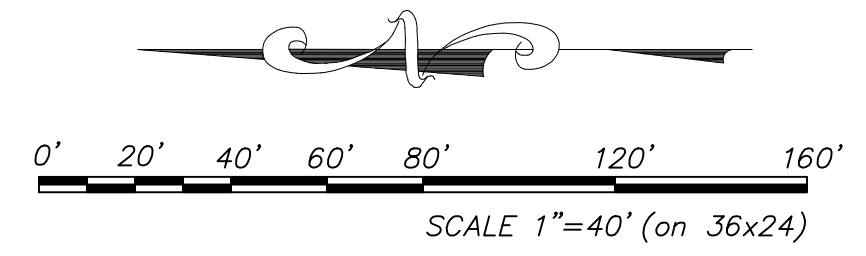

- GEOCON LEGEND**
- Qvop.....VERY OLD PARALAC DEPOSITS
 - Tt.....TORREY SANDSTONE (Dotted Where Buried)
 - T-11.....APPROX. LOCATION OF EXPLORATORY TRENCH
 - I-1.....APPROX. LOCATION OF INFILTRATION TEST
 - B-4.....APPROX. LOCATION OF DRY WELL INFILTRATION TEST
 - (1.0).....APPROX. DEPTH TO FORMATIONAL MATERIALS (In Feet)
 - 2.....APPROX. LOCATION OF GEOLOGIC CROSS SECTIONS

GEOLOGIC MAP
TORREY CREST
1220 - 1240 MELBA ROAD AND 1190 ISLAND VIEW LANE
ENCINITAS, CALIFORNIA

| | | |
|--|---|---------------------------------|
| GEOCON INCORPORATED GEOLOGICAL ■ ENVIRONMENTAL ■ MATERIALS 6740 FLANDERS DRIVE - SAN DIEGO, CALIFORNIA 92121 - 2974 PHONE 658 558-6900 - FAX 658 558-6159 | SCALE 1" = 40' PROJECT NO. G2438 - 52 - 01 SHEET 1 OF 1 | DATE 04 - 05 - 2023 FIGURE 1 |
|--|---|---------------------------------|

Printed: 04/04/2023 2:17PM | By: ALVIN LACROIX | File Location: Y:\PROJECTS\G2438-52-01 (Shaw Property)\SHEET\G2438-52-01 Geo Map.dwg

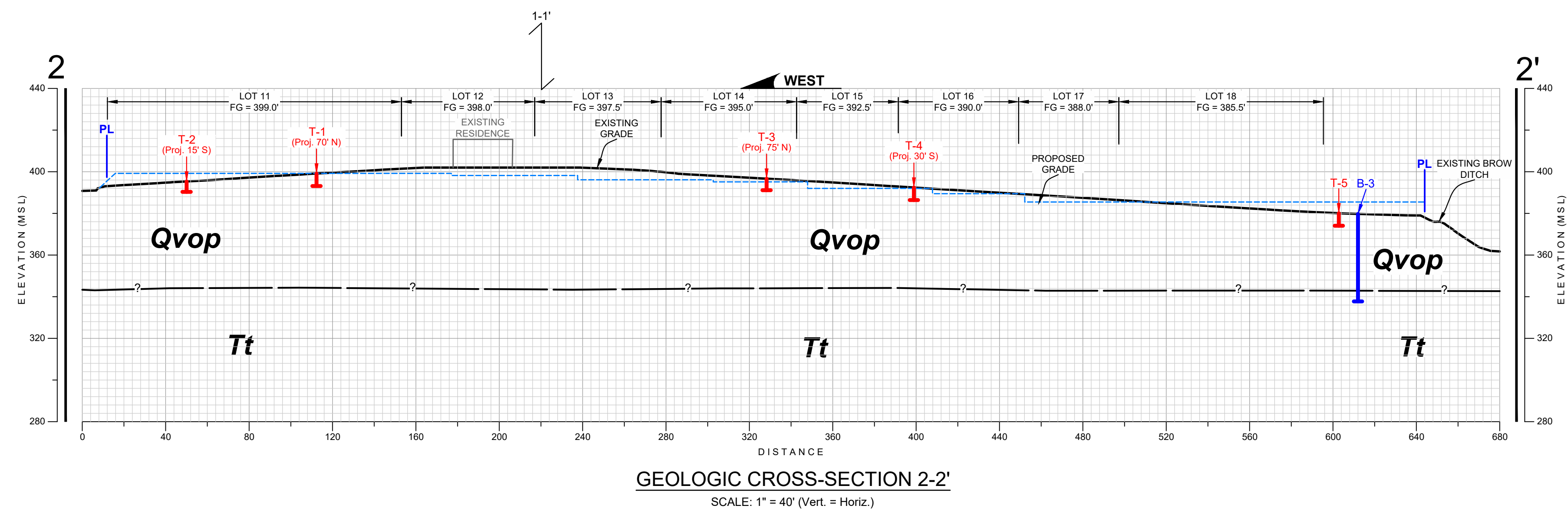
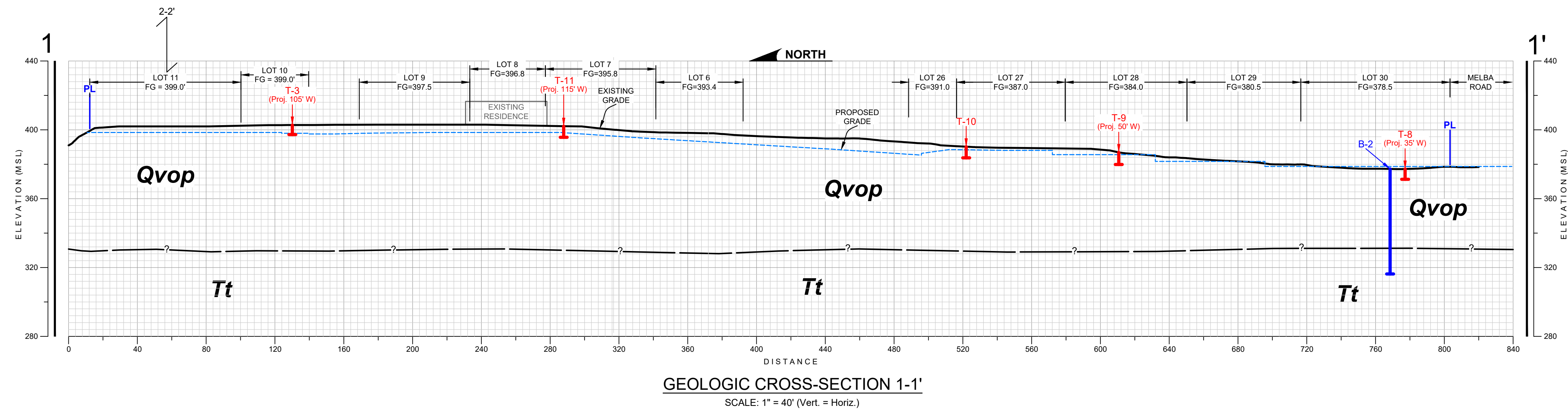

- GEOCON LEGEND**
- Qvop**VERY OLD PARALIC DEPOSITS
 - Tt**TORREY SANDSTONE
 - T-11**APPROX. LOCATION OF EXPLORATORY TRENCH
 - B-3**APPROX. LOCATION OF BORING
 - ?**APPROX. LOCATION OF GEOLOGIC CONTACT (Queried Where Uncertain)

GEOLOGIC CROSS - SECTIONS
TORREY CREST
1220 - 1240 MELBA ROAD AND 1190 ISLAND VIEW LANE
ENCINITAS, CALIFORNIA

| | | |
|---|-----------------------------|---------------------|
| GEOCON INCORPORATED GEOTECHNICAL ■ ENVIRONMENTAL ■ MATERIALS 6940 FLANDERS DRIVE - SAN DIEGO, CALIFORNIA 92121 - 2974 PHONE 658-558-6900 - FAX 658-558-6159 | SCALE 1" = 40' | DATE 04 - 05 - 2023 |
| | PROJECT NO. G2438 - 52 - 01 | FIGURE 2 |
| SHEET 1 OF 1 | | |

APPENDIX

A

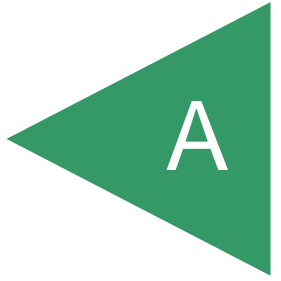

APPENDIX A

FIELD INVESTIGATION

We performed our field investigation on August 30, 2019, consisting of the excavation of 14 backhoe trenches. The backhoe trenches were excavated to a maximum depth of 7 feet using a John Deer 310 rubber-tire backhoe equipped with 24-inch wide bucket. During the trenching operations, we logged and sampled the soil and geologic conditions encountered. The infiltration-test borings (I-1 through I-4) were hand-augured to a depth of approximately 4 feet. Additionally, we performed drilling operations on June 16, 2021, through June 18, 2021. The Geologic Map, Figure 1, shows the approximate locations of the exploratory trenches, and borings. The boring and trench logs are presented in this Appendix. We located the borings and trenches in the field using a measuring tape and existing reference points; therefore, actual boring locations may deviate slightly. The geotechnical borings were drilled to a depth of approximately 60 to 66½ feet below existing grade using a Marl 5 and Marl 10 drill rig equipped with hollow-stem augers.

We obtained samples during our subsurface exploration in the borings using a Standard Penetration Test (SPT) sampler that are composed of steel and are driven to obtain samples. The SPT sampler has an inside diameter of 1.5 inches and an outside diameter of 2 inches. We obtained ring samples at appropriate intervals, placed them in moisture-tight containers, and transported them to the laboratory for testing. The type of sample is noted on the exploratory boring logs.







The samplers were driven 12 inches. The sampler is connected to A rods and driven into the bottom of the excavation using a 140-pound hammer with a 30-inch drop. Blow counts are recorded for every 6 inches the sampler is driven. The penetration resistances shown on the boring logs are shown in terms of blows per foot. The values indicated on the boring logs are the sum of the last 12 inches of the sampler. If the sampler was not driven for 12 inches, an approximate value is calculated in term of blows per foot or the final 6-inch interval is reported. These values are not to be taken as N-values as adjustments have not been applied. We estimated elevations shown on the boring logs either from a topographic map or by using a benchmark. Each excavation was backfilled as noted on the boring logs.

We visually examined, classified, and logged the soil encountered in the borings in general accordance with American Society for Testing and Materials (ASTM) practice for Description and Identification of Soils (Visual-Manual Procedure D 2488). The logs depict the soil and geologic conditions observed and the depth at which samples were obtained.

| DEPTH IN FEET | SAMPLE NO. | LITHOLOGY | GROUNDWATER | SOIL CLASS (USCS) | BORING B 1 | | PENETRATION RESISTANCE (BLOWS/FT.) | DRY DENSITY (P.C.F.) | MOISTURE CONTENT (%) |
|----------------------|---------------|-----------|-------------|-------------------------|---|----------------------------------|--|-------------------------|-------------------------|
| | | | | | ELEV. (MSL.) <u>376'</u> | DATE COMPLETED <u>06-16-2021</u> | | | |
| | | | | | EQUIPMENT <u>MARL 10 W/ 8" HSA</u> | | BY: <u>M. ERTWINE</u> | | |
| MATERIAL DESCRIPTION | | | | | | | | | |
| 0 | | | | | | | | | |
| 2 | | | | SM | VERY OLD PARALIC DEPOSITS (Qvop) Loose, dry, reddish brown, Silty SAND Dense, damp, light reddish brown, Silty, fine SAND -Becomes very dense | | | | |
| 4 | | | | | | | | | |
| 6 | | | | | | | | | |
| 8 | | | | | | | | | |
| 10 | | | | | | | | | |
| 12 | | | | | | | | | |
| 14 | | | | | | | | | |
| 16 | | | | | | | | | |
| 18 | | | | | | | | | |
| 20 | | | | | | | | | |
| 22 | | | | | | | | | |
| 24 | | | | | | | | | |
| 26 | | | | | | | | | |
| 28 | | | | | | | | | |
| 30 | B1-1 | | | SM | -Excavates to a silty to clayey fine sand Dense to medium dense, damp, reddish brown, Silty, fine to medium SAND | | 40 | | |
| 32 | | | | | | | | | |
| 34 | | | | | | | | | |
| 36 | | | | | | | | | |
| 38 | | | | | | | | | |

Figure A-1,
Log of Boring B 1, Page 1 of 2

G2438-52-01.GPJ

| | | | |
|----------------|---|---|--|
| SAMPLE SYMBOLS |  ... SAMPLING UNSUCCESSFUL |  ... STANDARD PENETRATION TEST |  ... DRIVE SAMPLE (UNDISTURBED) |
| |  ... DISTURBED OR BAG SAMPLE |  ... CHUNK SAMPLE |  ... WATER TABLE OR  ... SEEPAGE |

NOTE: THE LOG OF SUBSURFACE CONDITIONS SHOWN HEREON APPLIES ONLY AT THE SPECIFIC BORING OR TRENCH LOCATION AND AT THE DATE INDICATED. IT IS NOT WARRANTED TO BE REPRESENTATIVE OF SUBSURFACE CONDITIONS AT OTHER LOCATIONS AND TIMES.

| DEPTH IN FEET | SAMPLE NO. | LITHOLOGY | GROUNDWATER | SOIL CLASS (USCS) | BORING B 1 | | PENETRATION RESISTANCE (BLOWS/FT.) | DRY DENSITY (P.C.F.) | MOISTURE CONTENT (%) |
|----------------------|---------------|-----------|-------------|-------------------------|---|----------------------------------|--|-------------------------|-------------------------|
| | | | | | ELEV. (MSL.) <u>376'</u> | DATE COMPLETED <u>06-16-2021</u> | | | |
| | | | | | EQUIPMENT <u>MARL 10 W/ 8" HSA</u> | | BY: <u>M. ERTWINE</u> | | |
| MATERIAL DESCRIPTION | | | | | | | | | |
| 40 | B1-2 | | | | -Trace gravel clasts | | 30 | | |
| 42 | | | | | | | | | |
| 44 | | | | | | | | | |
| 46 | | | | | | | | | |
| 48 | | | | | | | | | |
| 50 | B1-3 | | | | TORREY SANDSTONE (Tt) Very dense, damp, light yellowish brown, Silty, fine grained SAND; trace gravel | | 68 | | |
| 52 | | | | | | | | | |
| 54 | | | | | | | | | |
| 56 | | | | | | | | | |
| 58 | | | | | | | | | |
| 60 | | | | SM | Very dense, damp, yellowish brown, Silty, fine-grained SANDSTONE | | 95/10" | | |
| | | | | | REFUSAL AT 60.9 FEET No groundwater Backfilled with 21 ft ³ of bentonite | | | | |

Figure A-1,
Log of Boring B 1, Page 2 of 2

G2438-52-01.GPJ







| | | | |
|----------------|-----------------------------|-------------------------------|---------------------------------|
| SAMPLE SYMBOLS | ... SAMPLING UNSUCCESSFUL | ... STANDARD PENETRATION TEST | ... DRIVE SAMPLE (UNDISTURBED) |
| | ... DISTURBED OR BAG SAMPLE | ... CHUNK SAMPLE | ... WATER TABLE OR ... SEEPAGE |

NOTE: THE LOG OF SUBSURFACE CONDITIONS SHOWN HEREON APPLIES ONLY AT THE SPECIFIC BORING OR TRENCH LOCATION AND AT THE DATE INDICATED. IT IS NOT WARRANTED TO BE REPRESENTATIVE OF SUBSURFACE CONDITIONS AT OTHER LOCATIONS AND TIMES.

| DEPTH IN FEET | SAMPLE NO. | LITHOLOGY | GROUNDWATER | SOIL CLASS (USCS) | BORING B 2 | | PENETRATION RESISTANCE (BLOWS/FT.) | DRY DENSITY (P.C.F.) | MOISTURE CONTENT (%) |
|----------------------|---------------|-----------|-------------|-------------------------|---|----------------------------------|--|-------------------------|-------------------------|
| | | | | | ELEV. (MSL.) <u>380'</u> | DATE COMPLETED <u>06-16-2021</u> | | | |
| | | | | | EQUIPMENT <u>MARL 10 W/ 8" HSA</u> | | BY: <u>M. ERTWINE</u> | | |
| MATERIAL DESCRIPTION | | | | | | | | | |
| 0 | | | | | <p>VERY OLD PARALIC DEPOSITS (Qvop) Medium dense to dense, moist, reddish brown, Silty, fine to medium SAND</p> <p style="text-align: center;">-Massive</p> | | | | |
| 2 | | | | | | | | | |
| 4 | | | | | | | | | |
| 6 | | | | | | | | | |
| 8 | | | | | | | | | |
| 10 | | | | | | | | | |
| 12 | | | | | | | | | |
| 14 | | | | | | | | | |
| 16 | | | | | | | | | |
| 18 | | | | | | | | | |
| 20 | | | | | | | | | |
| 22 | | | | | | | | | |
| 24 | | | | | | | | | |
| 26 | | | | | | | | | |
| 28 | | | | | | | | | |
| 30 | | | | | | | | | |
| 32 | | | | | | | | | |
| 34 | | | | | | | | | |
| 36 | | | | | | | | | |
| 38 | | | | | | | | | |

Figure A-2,
Log of Boring B 2, Page 1 of 2

G2438-52-01.GPJ

| | | | |
|----------------|---|---|--|
| SAMPLE SYMBOLS |  ... SAMPLING UNSUCCESSFUL |  ... STANDARD PENETRATION TEST |  ... DRIVE SAMPLE (UNDISTURBED) |
| |  ... DISTURBED OR BAG SAMPLE |  ... CHUNK SAMPLE |  ... WATER TABLE OR  ... SEEPAGE |

NOTE: THE LOG OF SUBSURFACE CONDITIONS SHOWN HEREON APPLIES ONLY AT THE SPECIFIC BORING OR TRENCH LOCATION AND AT THE DATE INDICATED. IT IS NOT WARRANTED TO BE REPRESENTATIVE OF SUBSURFACE CONDITIONS AT OTHER LOCATIONS AND TIMES.









| DEPTH IN FEET | SAMPLE NO. | LITHOLOGY | GROUNDWATER | SOIL CLASS (USCS) | BORING B 2 | | PENETRATION RESISTANCE (BLOWS/FT.) | DRY DENSITY (P.C.F.) | MOISTURE CONTENT (%) | |
|----------------------|---------------|---|-------------|-------------------------|---|----------------------------------|--|-------------------------|-------------------------|--|
| | | | | | ELEV. (MSL.) <u>380'</u> | DATE COMPLETED <u>06-16-2021</u> | | | | |
| | | | | | EQUIPMENT <u>MARL 10 W/ 8" HSA</u> | | BY: <u>M. ERTWINE</u> | | | |
| MATERIAL DESCRIPTION | | | | | | | | | | |
| 40 | | | | | | | | | | |
| 42 | | | | | | | | | | |
| 44 | | | | | | | | | | |
| 46 | | | | | | | | | | |
| 48 | | | | | | | | | | |
| 50 | B2-1 |  | | | | | 79 | | | |
| 52 | | | | | | | | | | |
| 54 | | | | | | | | | | |
| 56 | B2-2 |  | | | | | 51 | | | |
| 58 | | | | | | | | | | |
| 60 | | | | | | | | | | |
| 62 | | | | | | | | | | |
| 64 | | | | | | | | | | |
| 66 | | | | | | | 82/11" | | | |
| | | | | | BORING TERMINATED AT 66.4 FEET No groundwater Backfilled with 23 ft ³ of bentonite grout | | | | | |

Figure A-2,
Log of Boring B 2, Page 2 of 2

G2438-52-01.GPJ







| | | | |
|-----------------------|---|---|--|
| SAMPLE SYMBOLS |  ... SAMPLING UNSUCCESSFUL |  ... STANDARD PENETRATION TEST |  ... DRIVE SAMPLE (UNDISTURBED) |
| |  ... DISTURBED OR BAG SAMPLE |  ... CHUNK SAMPLE |  ... WATER TABLE OR  ... SEEPAGE |

NOTE: THE LOG OF SUBSURFACE CONDITIONS SHOWN HEREON APPLIES ONLY AT THE SPECIFIC BORING OR TRENCH LOCATION AND AT THE DATE INDICATED. IT IS NOT WARRANTED TO BE REPRESENTATIVE OF SUBSURFACE CONDITIONS AT OTHER LOCATIONS AND TIMES.

| DEPTH IN FEET | SAMPLE NO. | LITHOLOGY | GROUNDWATER | SOIL CLASS (USCS) | BORING B 3 | | PENETRATION RESISTANCE (BLOWS/FT.) | DRY DENSITY (P.C.F.) | MOISTURE CONTENT (%) |
|----------------------|---------------|-----------|-------------|-------------------------|---|----------------------------------|--|-------------------------|-------------------------|
| | | | | | ELEV. (MSL.) <u>380'</u> | DATE COMPLETED <u>06-17-2021</u> | | | |
| | | | | | EQUIPMENT <u>MARL 5 W/ 8" HSA</u> | | BY: <u>M. ERTWINE</u> | | |
| MATERIAL DESCRIPTION | | | | | | | | | |
| 0 | | | | | VERY OLD PARALIC DEPOSITS (Qvop) | | | | |
| 2 | | | | | Loose, dry, reddish brown, Silty, fine SAND | | | | |
| 4 | | | | | | | | | |
| 6 | | | | | | | | | |
| 8 | | | | | | | | | |
| 10 | | | | | | | | | |
| 12 | | | | | -Becomes very dense, excavates to a light reddish brown, silty, fine to medium sand | | | | |
| 14 | | | | | | | | | |
| 16 | | | | | | | | | |
| 18 | | | | | | | | | |
| 20 | | | | | | | | | |
| 22 | | | | | | | | | |
| 24 | | | | | | | | | |
| 26 | | | | | | | | | |
| 28 | | | | | | | | | |
| 30 | B3-1 | | | | Very dense to dense, moist, reddish brown, Silty to Clayey, fine to medium SAND | | 79 | | |
| 32 | | | | | | | | | |
| 34 | | | | | | | | | |
| 36 | | | | | | | | | |
| 38 | | | | | | | | | |

Figure A-3,
Log of Boring B 3, Page 1 of 2

G2438-52-01.GPJ

| | | | |
|----------------|---|---|--|
| SAMPLE SYMBOLS |  ... SAMPLING UNSUCCESSFUL |  ... STANDARD PENETRATION TEST |  ... DRIVE SAMPLE (UNDISTURBED) |
| |  ... DISTURBED OR BAG SAMPLE |  ... CHUNK SAMPLE |  ... WATER TABLE OR  ... SEEPAGE |

NOTE: THE LOG OF SUBSURFACE CONDITIONS SHOWN HEREON APPLIES ONLY AT THE SPECIFIC BORING OR TRENCH LOCATION AND AT THE DATE INDICATED. IT IS NOT WARRANTED TO BE REPRESENTATIVE OF SUBSURFACE CONDITIONS AT OTHER LOCATIONS AND TIMES.











| DEPTH IN FEET | SAMPLE NO. | LITHOLOGY | GROUNDWATER | SOIL CLASS (USCS) | BORING B 3 | | PENETRATION RESISTANCE (BLOWS/FT.) | DRY DENSITY (P.C.F.) | MOISTURE CONTENT (%) |
|----------------------|---------------|---|-------------|-------------------------|---|--|--|-------------------------|-------------------------|
| | | | | | ELEV. (MSL.) <u>380'</u> | DATE COMPLETED <u>06-17-2021</u> | | | |
| | | | | | EQUIPMENT <u>MARL 5 W/ 8" HSA</u> | | BY: <u>M. ERTWINE</u> | | |
| MATERIAL DESCRIPTION | | | | | | | | | |
| 40 | B3-2 |  | | | | | 37 | | |
| 42 | | | | | | | | | |
| 44 | | | | | | | | | |
| 46 | | | | | | | | | |
| 48 | | | | | | | | | |
| 50 | B3-3 |  | | | | Very dense, moist, reddish brown, Silty to Clayey, fine to coarse SAND; trace gravel | 65/11" | | |
| 52 | | | | | | TORREY SANDSTONE (Tt) Dense, moist, light yellowish to gray brown, Silty, fine-grained SANDSTONE | | | |
| 54 | | | | | | | | | |
| 56 | | | | | | | | | |
| 58 | | | | | | | | | |
| 60 | B3-4 |  | | | | | 85/9" | | |
| | | | | | BORING TERMINATED AT 61.3 FEET No groundwater Backfilled with 21 ft ³ of bentonite grout | | | | |

Figure A-3,
Log of Boring B 3, Page 2 of 2

G2438-52-01.GPJ







| | | | |
|-----------------------|---|---|--|
| SAMPLE SYMBOLS |  ... SAMPLING UNSUCCESSFUL |  ... STANDARD PENETRATION TEST |  ... DRIVE SAMPLE (UNDISTURBED) |
| |  ... DISTURBED OR BAG SAMPLE |  ... CHUNK SAMPLE |  ... WATER TABLE OR  ... SEEPAGE |

NOTE: THE LOG OF SUBSURFACE CONDITIONS SHOWN HEREON APPLIES ONLY AT THE SPECIFIC BORING OR TRENCH LOCATION AND AT THE DATE INDICATED. IT IS NOT WARRANTED TO BE REPRESENTATIVE OF SUBSURFACE CONDITIONS AT OTHER LOCATIONS AND TIMES.

| DEPTH IN FEET | SAMPLE NO. | LITHOLOGY | GROUNDWATER | SOIL CLASS (USCS) | BORING B 4 | | PENETRATION RESISTANCE (BLOWS/FT.) | DRY DENSITY (P.C.F.) | MOISTURE CONTENT (%) |
|----------------------|---------------|--|-------------|-------------------------|--|----------------------------------|--|-------------------------|-------------------------|
| | | | | | ELEV. (MSL.) <u>380'</u> | DATE COMPLETED <u>06-18-2021</u> | | | |
| | | | | | EQUIPMENT <u>MARL 5 W/ 8" HSA</u> | | BY: <u>M. ERTWINE</u> | | |
| MATERIAL DESCRIPTION | | | | | | | | | |
| 0 | | [Lithology pattern: fine sand with silt] | | | <p>VERY OLD PARALIC DEPOSITS (Tt) Medium dense, moist, reddish brown, Silty fine to medium SAND</p> <p>-Becomes very dense</p> <p>-Massive</p> | | | | |
| 2 | | | | | | | | | |
| 4 | | | | | | | | | |
| 6 | | | | | | | | | |
| 8 | | | | | | | | | |
| 10 | | | | | | | | | |
| 12 | | | | | | | | | |
| 14 | | | | | | | | | |
| 16 | | | | | | | | | |
| 18 | | | | | | | | | |
| 20 | | | | | | | | | |
| 22 | | | | | | | | | |
| 24 | | | | | | | | | |
| 26 | | | | | | | | | |
| 28 | | | | | | | | | |
| 30 | | | | | | | | | |
| 32 | | | | | | | | | |
| 34 | | | | | | | | | |
| 36 | | | | | | | | | |
| 38 | | | | | | | | | |

Figure A-4,
Log of Boring B 4, Page 1 of 2

G2438-52-01.GPJ

| | | | |
|----------------|---|---|--|
| SAMPLE SYMBOLS |  ... SAMPLING UNSUCCESSFUL |  ... STANDARD PENETRATION TEST |  ... DRIVE SAMPLE (UNDISTURBED) |
| |  ... DISTURBED OR BAG SAMPLE |  ... CHUNK SAMPLE |  ... WATER TABLE OR  ... SEEPAGE |

NOTE: THE LOG OF SUBSURFACE CONDITIONS SHOWN HEREON APPLIES ONLY AT THE SPECIFIC BORING OR TRENCH LOCATION AND AT THE DATE INDICATED. IT IS NOT WARRANTED TO BE REPRESENTATIVE OF SUBSURFACE CONDITIONS AT OTHER LOCATIONS AND TIMES.







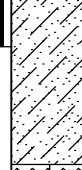

| DEPTH IN FEET | SAMPLE NO. | LITHOLOGY | GROUNDWATER | SOIL CLASS (USCS) | BORING B 4 | | PENETRATION RESISTANCE (BLOWS/FT.) | DRY DENSITY (P.C.F.) | MOISTURE CONTENT (%) |
|----------------------|---------------|--|-------------|-------------------------|---|----------------------------------|--|-------------------------|-------------------------|
| | | | | | ELEV. (MSL.) <u>380'</u> | DATE COMPLETED <u>06-18-2021</u> | | | |
| | | | | | EQUIPMENT <u>MARL 5 W/ 8" HSA</u> | | BY: <u>M. ERTWINE</u> | | |
| MATERIAL DESCRIPTION | | | | | | | | | |
| 40 | | | | | | | | | |
| 42 | | | | | | | | | |
| 44 | | | | | | | | | |
| 46 | | | | | | | | | |
| 48 | | | | | | | | | |
| 50 | B4-1 |  | | SC | Very dense, moist, dark reddish brown, Clayey, fine to coarse SAND | | 88 | | |
| 52 | | | | | | | | | |
| 54 | | | | | | | | | |
| 56 | | | | SM | TORREY SANDSTONE (Tt) Very dense, moist, light yellowish to grayish brown, Silty fine grained SANDSTONE | | | | |
| 58 | | | | | | | | | |
| 60 | B4-2 |  | | | | | 72/10" | | |
| 62 | | | | | | | | | |
| 64 | | | | | | | | | |
| | | | | | BORING TERMINATED AT 65 FEET No groundwater Backfilled with 22 ft ³ of bentonite grout | | | | |

Figure A-4,
Log of Boring B 4, Page 2 of 2

G2438-52-01.GPJ

| | | | | | | |
|----------------|---|-----------------------------|---|-------------------------------|---|--|
| SAMPLE SYMBOLS |  | ... SAMPLING UNSUCCESSFUL |  | ... STANDARD PENETRATION TEST |  | ... DRIVE SAMPLE (UNDISTURBED) |
| |  | ... DISTURBED OR BAG SAMPLE |  | ... CHUNK SAMPLE |  | ... WATER TABLE OR  ... SEEPAGE |

NOTE: THE LOG OF SUBSURFACE CONDITIONS SHOWN HEREON APPLIES ONLY AT THE SPECIFIC BORING OR TRENCH LOCATION AND AT THE DATE INDICATED. IT IS NOT WARRANTED TO BE REPRESENTATIVE OF SUBSURFACE CONDITIONS AT OTHER LOCATIONS AND TIMES.









| DEPTH IN FEET | SAMPLE NO. | LITHOLOGY | GROUNDWATER | SOIL CLASS (USCS) | TRENCH T 1 | | PENETRATION RESISTANCE (BLOWS/FT.) | DRY DENSITY (P.C.F.) | MOISTURE CONTENT (%) |
|----------------------|---------------|--|-------------|-------------------------|---|----------------------------------|--|-------------------------|-------------------------|
| | | | | | ELEV. (MSL.) <u>399'</u> | DATE COMPLETED <u>08-30-2019</u> | | | |
| | | | | | EQUIPMENT <u>JD 310 BACKHOE</u> BY: <u>M. ERTWINE</u> | | | | |
| MATERIAL DESCRIPTION | | | | | | | | | |
| 0 | | | | SM | TOPSOIL Loose, dry, grayish brown, Silty SAND; few organics | | | | |
| | T1-1 |  | | SM | VERY OLD PARALIC DEPOSITS (Qvop) Medium dense, moist, reddish brown, Silty, fine grained SANDSTONE; friable; highly weathered; weakly cemented; trace rootlets | | | | |
| 2 | | | | | | | | | |
| 4 | T1-2 |  | | SM | Dense, moist, yellowish to reddish brown, Silty, fine- to medium-grained SANDSTONE; moderately weathered; moderately to strongly cemented | | | 122.7 | 7.2 |
| 6 | | | | | TRENCH TERMINATED AT 6 FEET Groundwater not encountered | | | | |

Figure A-1,
Log of Trench T 1, Page 1 of 1

G2438-52-01.GPJ

| | | | | | | |
|----------------|---|-----------------------------|---|-------------------------------|---|--|
| SAMPLE SYMBOLS |  | ... SAMPLING UNSUCCESSFUL |  | ... STANDARD PENETRATION TEST |  | ... DRIVE SAMPLE (UNDISTURBED) |
| |  | ... DISTURBED OR BAG SAMPLE |  | ... CHUNK SAMPLE |  | ... WATER TABLE OR  ... SEEPAGE |

NOTE: THE LOG OF SUBSURFACE CONDITIONS SHOWN HEREON APPLIES ONLY AT THE SPECIFIC BORING OR TRENCH LOCATION AND AT THE DATE INDICATED. IT IS NOT WARRANTED TO BE REPRESENTATIVE OF SUBSURFACE CONDITIONS AT OTHER LOCATIONS AND TIMES.

| DEPTH IN FEET | SAMPLE NO. | LITHOLOGY | GROUNDWATER | SOIL CLASS (USCS) | TRENCH T 2 | | PENETRATION RESISTANCE (BLOWS/FT.) | DRY DENSITY (P.C.F.) | MOISTURE CONTENT (%) | |
|----------------------|---------------|-----------|-------------|-------------------------|--|----------------------------------|--|-------------------------|-------------------------|--|
| | | | | | ELEV. (MSL.) <u>395'</u> | DATE COMPLETED <u>08-30-2019</u> | | | | |
| | | | | | EQUIPMENT <u>JD 310 BACKHOE</u> | | BY: <u>M. ERTWINE</u> | | | |
| MATERIAL DESCRIPTION | | | | | | | | | | |
| 0 | | | | SM | TOPSOIL Loose, dry, yellowish brown, Silty, fine SAND; trace organics | | | | | |
| | T2-1 | | | SM | VERY OLD PARALIC DEPOSITS (Qvop) Medium dense to dense, damp, light reddish brown, Silty, fine- to medium-grained SANDSTONE; highly weathered; weakly cemented; trace rootlets | | | | | |
| 2 | | | | | | | | | | |
| 4 | T2-2 | | | | -Becomes moderately weathered, moderately to strongly cemented | | | 118.1 | 6.2 | |
| | | | | | PRACTICAL REFUSAL AT 5 FEET Groundwater not encountered | | | | | |

Figure A-2,
Log of Trench T 2, Page 1 of 1

G2438-52-01.GPJ

| | | | | | | |
|-----------------------|--|-----------------------------|--|-------------------------------|--|--------------------------------|
| SAMPLE SYMBOLS | | ... SAMPLING UNSUCCESSFUL | | ... STANDARD PENETRATION TEST | | ... DRIVE SAMPLE (UNDISTURBED) |
| | | ... DISTURBED OR BAG SAMPLE | | ... CHUNK SAMPLE | | ... WATER TABLE OR ... SEEPAGE |

NOTE: THE LOG OF SUBSURFACE CONDITIONS SHOWN HEREON APPLIES ONLY AT THE SPECIFIC BORING OR TRENCH LOCATION AND AT THE DATE INDICATED. IT IS NOT WARRANTED TO BE REPRESENTATIVE OF SUBSURFACE CONDITIONS AT OTHER LOCATIONS AND TIMES.

| DEPTH IN FEET | SAMPLE NO. | LITHOLOGY | GROUNDWATER | SOIL CLASS (USCS) | TRENCH T 3 | | PENETRATION RESISTANCE (BLOWS/FT.) | DRY DENSITY (P.C.F.) | MOISTURE CONTENT (%) |
|----------------------|---------------|-----------|-------------|-------------------------|--|----------------------------------|--|-------------------------|-------------------------|
| | | | | | ELEV. (MSL.) <u>397'</u> | DATE COMPLETED <u>08-30-2019</u> | | | |
| | | | | | EQUIPMENT <u>JD 310 BACKHOE</u> BY: <u>M. ERTWINE</u> | | | | |
| MATERIAL DESCRIPTION | | | | | | | | | |
| 0 | | | | SM | TOPSOIL Loose, dry, yellowish brown, Silty, fine SAND; trace organics | | | | |
| | | | | SM | VERY OLD PARALIC DEPOSITS (Qvop) Medium dense, damp, yellowish brown, Silty, fine grained SANDSTONE; highly weathered; weakly cemented; trace rootlets; few krotovina | | | | |
| 2 | T3-1 | | | | | | | | |
| 4 | | | | | -Becomes dense, reddish brown; moderately cemented | | | | |
| | | | | | -Becomes strongly cemented | | | | |
| | | | | | PRACTICAL REFUSAL AT 5 FEET Groundwater not encountered | | | | |

Figure A-3,
Log of Trench T 3, Page 1 of 1

G2438-52-01.GPJ







| | | | | | | |
|----------------|--|-----------------------------|--|-------------------------------|--|--------------------------------|
| SAMPLE SYMBOLS | | ... SAMPLING UNSUCCESSFUL | | ... STANDARD PENETRATION TEST | | ... DRIVE SAMPLE (UNDISTURBED) |
| | | ... DISTURBED OR BAG SAMPLE | | ... CHUNK SAMPLE | | ... WATER TABLE OR ... SEEPAGE |

NOTE: THE LOG OF SUBSURFACE CONDITIONS SHOWN HEREON APPLIES ONLY AT THE SPECIFIC BORING OR TRENCH LOCATION AND AT THE DATE INDICATED. IT IS NOT WARRANTED TO BE REPRESENTATIVE OF SUBSURFACE CONDITIONS AT OTHER LOCATIONS AND TIMES.

| DEPTH IN FEET | SAMPLE NO. | LITHOLOGY | GROUNDWATER | SOIL CLASS (USCS) | TRENCH T 4 | | PENETRATION RESISTANCE (BLOWS/FT.) | DRY DENSITY (P.C.F.) | MOISTURE CONTENT (%) |
|----------------------|---------------|-----------|-------------|-------------------------|--|----------------------------------|--|-------------------------|-------------------------|
| | | | | | ELEV. (MSL.) <u>392'</u> | DATE COMPLETED <u>08-30-2019</u> | | | |
| | | | | | EQUIPMENT <u>JD 310 BACKHOE</u> | | BY: <u>M. ERTWINE</u> | | |
| MATERIAL DESCRIPTION | | | | | | | | | |
| 0 | | | | SM | TOPSOIL Loose, moist, yellowish brown, Silty, fine SAND; trace debris and organics | | | | |
| 2 | | | | SM | VERY OLD PARALIC DEPOSITS (Qvop) Medium dense, damp, yellowish to reddish brown, Silty, fine grained SANDSTONE; trace rootlets; highly weathered; weakly cemented -Becomes dense, moist, reddish to grayish brown, fine- to medium-grained; moderately weathered; moderately cemented | | | | |
| 4 | | | | | | | | | |
| 6 | | | | | PRACTICAL REFUSAL AT 6 FEET Groundwater not encountered | | | | |

Figure A-4,
Log of Trench T 4, Page 1 of 1

G2438-52-01.GPJ

| | | | |
|----------------|---|---|--|
| SAMPLE SYMBOLS |  ... SAMPLING UNSUCCESSFUL |  ... STANDARD PENETRATION TEST |  ... DRIVE SAMPLE (UNDISTURBED) |
| |  ... DISTURBED OR BAG SAMPLE |  ... CHUNK SAMPLE |  ... WATER TABLE OR  ... SEEPAGE |

NOTE: THE LOG OF SUBSURFACE CONDITIONS SHOWN HEREON APPLIES ONLY AT THE SPECIFIC BORING OR TRENCH LOCATION AND AT THE DATE INDICATED. IT IS NOT WARRANTED TO BE REPRESENTATIVE OF SUBSURFACE CONDITIONS AT OTHER LOCATIONS AND TIMES.









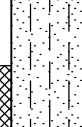

| DEPTH IN FEET | SAMPLE NO. | LITHOLOGY | GROUNDWATER | SOIL CLASS (USCS) | TRENCH T 5 | | PENETRATION RESISTANCE (BLOWS/FT.) | DRY DENSITY (P.C.F.) | MOISTURE CONTENT (%) |
|----------------------|------------|--|-------------|-------------------|---|----------------------------------|------------------------------------|----------------------|----------------------|
| | | | | | ELEV. (MSL.) <u>380'</u> | DATE COMPLETED <u>08-30-2019</u> | | | |
| | | | | | EQUIPMENT <u>JD 310 BACKHOE</u> | | BY: <u>M. ERTWINE</u> | | |
| MATERIAL DESCRIPTION | | | | | | | | | |
| 0 | T5-1 |  | | SM | TOPSOIL Loose, moist, yellowish brown, Silty SAND; trace organics | | | | |
| 2 | T5-2 |  | | SM | VERY OLD PARALIC DEPOSITS (Qvop) Medium dense, moist, light reddish brown, Silty, fine grained SANDSTONE; highly weathered; weakly cemented; trace rootlets | | | | |
| | | | | SC | Dense, moist, light reddish brown mottled with grayish brown, Clayey, fine to medium SANDSTONE; moderately weathered | | | | |
| 4 | T5-3 |  | | SM | Dense, moist, reddish brown, Silty, fine- to medium-grained SANDSTONE; moderately weathered, moderately to strongly cemented | | | | |
| | | | | | | | 127.0 | 7.4 | |
| 6 | | | | | PRACTICAL REFUSAL AT 6 FEET Groundwater not encountered | | | | |

Figure A-5,
Log of Trench T 5, Page 1 of 1

G2438-52-01.GPJ

| | | | | | | |
|----------------|---|-----------------------------|---|-------------------------------|---|--|
| SAMPLE SYMBOLS |  | ... SAMPLING UNSUCCESSFUL |  | ... STANDARD PENETRATION TEST |  | ... DRIVE SAMPLE (UNDISTURBED) |
| |  | ... DISTURBED OR BAG SAMPLE |  | ... CHUNK SAMPLE |  | ... WATER TABLE OR  ... SEEPAGE |

NOTE: THE LOG OF SUBSURFACE CONDITIONS SHOWN HEREON APPLIES ONLY AT THE SPECIFIC BORING OR TRENCH LOCATION AND AT THE DATE INDICATED. IT IS NOT WARRANTED TO BE REPRESENTATIVE OF SUBSURFACE CONDITIONS AT OTHER LOCATIONS AND TIMES.









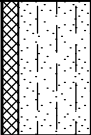
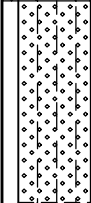

| DEPTH IN FEET | SAMPLE NO. | LITHOLOGY | GROUNDWATER | SOIL CLASS (USCS) | TRENCH T 6 | | PENETRATION RESISTANCE (BLOWS/FT.) | DRY DENSITY (P.C.F.) | MOISTURE CONTENT (%) | |
|---------------------|---------------|--|-------------|-------------------------|--|----------------------------------|--|-------------------------|-------------------------|--|
| | | | | | ELEV. (MSL.) 382' | DATE COMPLETED 08-30-2019 | | | | |
| | | | | | EQUIPMENT JD 310 BACKHOE BY: M. ERTWINE | | | | | |
| | | | | | MATERIAL DESCRIPTION | | | | | |
| 0 | T6-1 |  | | SM | TOPSOIL Loose, dry, yellowish brown, Silty, fine SAND; trace organics | | | | | |
| 2 | |  | | SM | VERY OLD PARALIC DEPOSITS (Qvop) Medium dense, moist, light reddish brown, Silty, fine grained SANDSTONE; highly weathered; weakly cemented; trace rootlets | | | | | |
| | |  | | SC | Dense, moist, reddish mottled grayish brown, Clayey, fine to medium SANDSTONE; moderately weathered; moderately cemented | | | | | |
| 4 | |  | | SM | Dense, moist, reddish brown, Silty, fine- to medium-grained SANDSTONE; moderately weathered; strongly cemented | | | | | |
| | | | | | PRACTICAL REFUSAL AT 5 FEET Groundwater not encountered | | | | | |

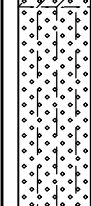
Figure A-6,
Log of Trench T 6, Page 1 of 1

G2438-52-01.GPJ

| | | | |
|-----------------------|---|---|--|
| SAMPLE SYMBOLS |  ... SAMPLING UNSUCCESSFUL |  ... STANDARD PENETRATION TEST |  ... DRIVE SAMPLE (UNDISTURBED) |
| |  ... DISTURBED OR BAG SAMPLE |  ... CHUNK SAMPLE |  ... WATER TABLE OR  ... SEEPAGE |

NOTE: THE LOG OF SUBSURFACE CONDITIONS SHOWN HEREON APPLIES ONLY AT THE SPECIFIC BORING OR TRENCH LOCATION AND AT THE DATE INDICATED. IT IS NOT WARRANTED TO BE REPRESENTATIVE OF SUBSURFACE CONDITIONS AT OTHER LOCATIONS AND TIMES.

| DEPTH IN FEET | SAMPLE NO. | LITHOLOGY | GROUNDWATER | SOIL CLASS (USCS) | TRENCH T 7 | | PENETRATION RESISTANCE (BLOWS/FT.) | DRY DENSITY (P.C.F.) | MOISTURE CONTENT (%) |
|----------------------|---------------|-----------|-------------|-------------------------|---|----------------------------------|--|-------------------------|-------------------------|
| | | | | | ELEV. (MSL.) <u>372'</u> | DATE COMPLETED <u>08-30-2019</u> | | | |
| | | | | | EQUIPMENT <u>JD 310 BACKHOE</u> BY: <u>M. ERTWINE</u> | | | | |
| MATERIAL DESCRIPTION | | | | | | | | | |
| 0 | | | | SM | TOPSOIL Loose, moist, reddish brown, Silty, fine SAND; trace rootlets | | | | |
| | T7-1 | | | SM | VERY OLD PARALIC DEPOSITS (Qvop) Medium dense, damp, light reddish brown, Silty, fine grained SANDSTONE; highly weathered; weakly cemented; few rootlets | | | | |
| 2 | | | | | | | | | |
| | T7-2 | | | SM | Dense, damp, reddish brown, Silty, fine grained SANDSTONE; moderately weathered; moderately to strongly cemented | | | | |
| 4 | | | | | | | | | |
| 6 | | | | | PRACTICAL REFUSAL AT 6 FEET Groundwater not encountered | | | | |

Figure A-7,
Log of Trench T 7, Page 1 of 1

G2438-52-01.GPJ

| | | | |
|----------------|-----------------------------|-------------------------------|---------------------------------|
| SAMPLE SYMBOLS | ... SAMPLING UNSUCCESSFUL | ... STANDARD PENETRATION TEST | ... DRIVE SAMPLE (UNDISTURBED) |
| | ... DISTURBED OR BAG SAMPLE | ... CHUNK SAMPLE | ... WATER TABLE OR ... SEEPAGE |

NOTE: THE LOG OF SUBSURFACE CONDITIONS SHOWN HEREON APPLIES ONLY AT THE SPECIFIC BORING OR TRENCH LOCATION AND AT THE DATE INDICATED. IT IS NOT WARRANTED TO BE REPRESENTATIVE OF SUBSURFACE CONDITIONS AT OTHER LOCATIONS AND TIMES.









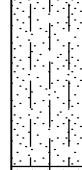

| DEPTH IN FEET | SAMPLE NO. | LITHOLOGY | GROUNDWATER | SOIL CLASS (USCS) | TRENCH T 8 | | PENETRATION RESISTANCE (BLOWS/FT.) | DRY DENSITY (P.C.F.) | MOISTURE CONTENT (%) |
|----------------------|---------------|--|-------------|-------------------------|---|----------------------------------|--|-------------------------|-------------------------|
| | | | | | ELEV. (MSL.) <u>378'</u> | DATE COMPLETED <u>08-30-2019</u> | | | |
| | | | | | EQUIPMENT <u>JD 310 BACKHOE</u> | | BY: <u>M. ERTWINE</u> | | |
| MATERIAL DESCRIPTION | | | | | | | | | |
| 0 | |  | | SM | TOPSOIL Loose, moist, light brown, Silty, fine SAND; trace organics | | | | |
| 2 | |  | | SM | VERY OLD PARALIC DEPOSITS (Qvop) Medium dense, damp, light reddish brown, Silty, fine-grained SANDSTONE; highly weathered; weakly cemented | | | | |
| 4 | |  | | SM/SC | Dense, moist, reddish brown, Silty to Clayey, fine- to medium-grained SANDSTONE; moderately weathered; moderately to strongly cemented | | | | |
| 6 | | | | | PRACTICAL REFUSAL AT 6 FEET Groundwater not encountered | | | | |

Figure A-8,
Log of Trench T 8, Page 1 of 1

G2438-52-01.GPJ







| | | | |
|----------------|---|---|--|
| SAMPLE SYMBOLS |  ... SAMPLING UNSUCCESSFUL |  ... STANDARD PENETRATION TEST |  ... DRIVE SAMPLE (UNDISTURBED) |
| |  ... DISTURBED OR BAG SAMPLE |  ... CHUNK SAMPLE |  ... WATER TABLE OR  ... SEEPAGE |

NOTE: THE LOG OF SUBSURFACE CONDITIONS SHOWN HEREON APPLIES ONLY AT THE SPECIFIC BORING OR TRENCH LOCATION AND AT THE DATE INDICATED. IT IS NOT WARRANTED TO BE REPRESENTATIVE OF SUBSURFACE CONDITIONS AT OTHER LOCATIONS AND TIMES.

| DEPTH IN FEET | SAMPLE NO. | LITHOLOGY | GROUNDWATER | SOIL CLASS (USCS) | TRENCH T 9 | | PENETRATION RESISTANCE (BLOWS/FT.) | DRY DENSITY (P.C.F.) | MOISTURE CONTENT (%) |
|----------------------|---------------|-----------|-------------|-------------------------|---|----------------------------------|--|-------------------------|-------------------------|
| | | | | | ELEV. (MSL.) <u>388'</u> | DATE COMPLETED <u>08-30-2019</u> | | | |
| | | | | | EQUIPMENT <u>JD 310 BACKHOE</u> | | BY: <u>M. ERTWINE</u> | | |
| MATERIAL DESCRIPTION | | | | | | | | | |
| 0 | | | | SM | TOPSOIL Loose, dry, yellowish brown, Silty, fine SAND; trace rootlets | | | | |
| 2 | T9-1 | | | SM | VERY OLD PARALIC DEPOSITS (Qvop) Medium dense, damp, light reddish brown, Silty, fine-grained SANDSTONE; highly weathered; weakly cemented; trace rootlets | | | | |
| 4 | T9-2 | | | | -Becomes dense, reddish brown, fine- to medium-grained; moderately weathered; moderately cemented | | | | |
| 6 | T9-3 | | | | -Becomes mottled reddish to grayish brown; strongly cemented; difficult excavation | | | 119.8 | 9.1 |
| | | | | | PRACTICAL REFUSAL AT 7 FEET Groundwater not encountered | | | | |

Figure A-9,
Log of Trench T 9, Page 1 of 1

G2438-52-01.GPJ

| | | | |
|----------------|---|---|--|
| SAMPLE SYMBOLS |  ... SAMPLING UNSUCCESSFUL |  ... STANDARD PENETRATION TEST |  ... DRIVE SAMPLE (UNDISTURBED) |
| |  ... DISTURBED OR BAG SAMPLE |  ... CHUNK SAMPLE |  ... WATER TABLE OR  ... SEEPAGE |

NOTE: THE LOG OF SUBSURFACE CONDITIONS SHOWN HEREON APPLIES ONLY AT THE SPECIFIC BORING OR TRENCH LOCATION AND AT THE DATE INDICATED. IT IS NOT WARRANTED TO BE REPRESENTATIVE OF SUBSURFACE CONDITIONS AT OTHER LOCATIONS AND TIMES.









| DEPTH IN FEET | SAMPLE NO. | LITHOLOGY | GROUNDWATER | SOIL CLASS (USCS) | TRENCH T 10 | | PENETRATION RESISTANCE (BLOWS/FT.) | DRY DENSITY (P.C.F.) | MOISTURE CONTENT (%) |
|----------------------|---------------|--|-------------|-------------------------|---|----------------------------------|--|-------------------------|-------------------------|
| | | | | | ELEV. (MSL.) <u>390'</u> | DATE COMPLETED <u>08-30-2019</u> | | | |
| | | | | | EQUIPMENT <u>JD 310 BACKHOE</u> BY: <u>M. ERTWINE</u> | | | | |
| MATERIAL DESCRIPTION | | | | | | | | | |
| 0 | T10-1 |  | | SM | TOPSOIL Loose, damp, yellowish brown, Silty, fine SAND; | | | | |
| | | | | SM | VERY OLD PARALIC DEPOSITS (Qvop) Medium dense, damp, light reddish brown, Silty, fine-grained SANDSTONE; highly weathered; weakly cemented; trace rootlets | | | | |
| 2 | | | | | -Becomes dense, moist, reddish brown, fine- to medium-grained; moderately weathered; moderately cemented | | | | |
| 4 | | | | | | | | | |
| 6 | | | | | -Becomes strongly cemented | | | | |
| | | | | | PRACTICAL REFUSAL AT 6.5 FEET Groundwater not encountered | | | | |

Figure A-10,
Log of Trench T 10, Page 1 of 1

G2438-52-01.GPJ

| | | | |
|----------------|---|---|--|
| SAMPLE SYMBOLS |  ... SAMPLING UNSUCCESSFUL |  ... STANDARD PENETRATION TEST |  ... DRIVE SAMPLE (UNDISTURBED) |
| |  ... DISTURBED OR BAG SAMPLE |  ... CHUNK SAMPLE |  ... WATER TABLE OR  ... SEEPAGE |

NOTE: THE LOG OF SUBSURFACE CONDITIONS SHOWN HEREON APPLIES ONLY AT THE SPECIFIC BORING OR TRENCH LOCATION AND AT THE DATE INDICATED. IT IS NOT WARRANTED TO BE REPRESENTATIVE OF SUBSURFACE CONDITIONS AT OTHER LOCATIONS AND TIMES.

| DEPTH IN FEET | SAMPLE NO. | LITHOLOGY | GROUNDWATER | SOIL CLASS (USCS) | TRENCH T 11 | | PENETRATION RESISTANCE (BLOWS/FT.) | DRY DENSITY (P.C.F.) | MOISTURE CONTENT (%) |
|----------------------|---------------|-----------|-------------|-------------------------|---|----------------------------------|--|-------------------------|-------------------------|
| | | | | | ELEV. (MSL.) <u>395'</u> | DATE COMPLETED <u>08-30-2019</u> | | | |
| | | | | | EQUIPMENT <u>JD 310 BACKHOE</u> BY: <u>M. ERTWINE</u> | | | | |
| MATERIAL DESCRIPTION | | | | | | | | | |
| 0 | T11-1 | | | SM | TOPSOIL Loose, moist, yellowish brown, Silty, fine SAND; trace rootlets | | | | |
| 2 | | | | SM | VERY OLD PARALIC DEPOSITS (Qvop) Medium dense, damp, light yellowish to reddish brown, Silty, fine- to medium-grained SANDSTONE; highly weathered; weakly cemented; trace rootlets -Becomes dense to very dense, moist, light reddish brown; moderately weathered; moderately to strongly cemented | | | | |
| 4 | | | | | | | | | |
| 6 | | | | | | | | | |
| | | | | | PRACTICAL REFUSAL AT 6.5 FEET Groundwater not encountered | | | | |

Figure A-11,
Log of Trench T 11, Page 1 of 1

G2438-52-01.GPJ

| | | | | | | |
|----------------|--|-----------------------------|--|-------------------------------|--|--------------------------------|
| SAMPLE SYMBOLS | | ... SAMPLING UNSUCCESSFUL | | ... STANDARD PENETRATION TEST | | ... DRIVE SAMPLE (UNDISTURBED) |
| | | ... DISTURBED OR BAG SAMPLE | | ... CHUNK SAMPLE | | ... WATER TABLE OR ... SEEPAGE |

NOTE: THE LOG OF SUBSURFACE CONDITIONS SHOWN HEREON APPLIES ONLY AT THE SPECIFIC BORING OR TRENCH LOCATION AND AT THE DATE INDICATED. IT IS NOT WARRANTED TO BE REPRESENTATIVE OF SUBSURFACE CONDITIONS AT OTHER LOCATIONS AND TIMES.

APPENDIX

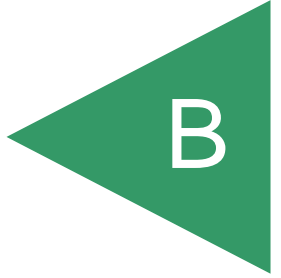

APPENDIX B

LABORATORY TESTING

We performed laboratory tests in accordance with generally accepted test methods of the American Society for Testing and Materials (ASTM) or other suggested procedures. Selected soil samples were tested for in-place dry density/moisture content, maximum density/optimum moisture content, direct shear strength, expansion index, water-soluble sulfate, R-Value, unconfined compressive strength, and gradation characteristics. The results of our current laboratory tests are presented herein. The in-place dry density and moisture content of chunk samples tested are presented on the boring logs in Appendix A.

SUMMARY OF LABORATORY MAXIMUM DRY DENSITY AND OPTIMUM MOISTURE CONTENT TEST RESULTS ASTM D 1557

| Sample No. | Description (Geologic Unit) | Maximum Dry Density (pcf) | Optimum Moisture Content (% dry wt.) |
|------------|---|---------------------------|--------------------------------------|
| T2-1 | Reddish brown, Silty, fine to medium SAND | 131.5 | 8.4 |
| T7-1 | Light reddish brown, Silty, fine to medium SAND | 131.9 | 8.4 |

SUMMARY OF LABORATORY DIRECT SHEAR TEST RESULTS ASTM D 3080

| Sample No. | Depth (feet) | Geologic Unit | Dry Density (pcf) | Moisture Content (%) | | Unit Peak [Ultimate ¹] Cohesion (psf) | Angle of Peak [Ultimate ¹] Shear Resistance (degrees) |
|------------|--------------|---------------|-------------------|----------------------|-------|---|---|
| | | | | Initial | Final | | |
| T2-1* | 1-3 | Qvop | 118.1 | 8.8 | 13.3 | 650 [395] | 31 [33] |
| T7-1* | 1-3.5 | Qvop | 118.3 | 9.0 | 13.9 | 295 [380] | 35 [30] |

* Sample remolded to 90 percent the maximum dry density.

¹ End of test at about 0.25 inches of deflection.

SUMMARY OF LABORATORY EXPANSION INDEX TEST RESULTS ASTM D 4829

| Sample No. | Moisture Content (%) | | Dry Density (pcf) | Expansion Index | 2019 CBC Expansion Classification | ASTM Soil Expansion Classification |
|------------|----------------------|------------|-------------------|-----------------|-----------------------------------|------------------------------------|
| | Before Test | After Test | | | | |
| T5-2 | 11.0 | 18.9 | 107.6 | 18 | Non-Expansive | Very Low |
| T9-1 | 9.8 | 17.4 | 110.5 | 4 | Non-Expansive | Very Low |
| T11-1 | 7.8 | 13.6 | 119.5 | 0 | Non-Expansive | Very Low |

**SUMMARY OF LABORATORY WATER-SOLUBLE SULFATE TEST RESULTS
CALIFORNIA TEST NO. 417**

| Sample No. | Depth (feet) | Geologic Unit | Water-Soluble Sulfate (%) | ACI 318 Sulfate Exposure |
|------------|--------------|---------------|---------------------------|--------------------------|
| B1-1 | 0-5 | Qudf | 0.004 | S0 |
| B5-1 | 0-5 | Qudf | 0.049 | S0 |

**SUMMARY OF LABORATORY RESISTANCE VALUE (R-VALUE) TEST RESULTS
ASTM D 2844**

| Sample No. | Depth (feet) | Description (Geologic Unit) | R-Value |
|------------|--------------|--|---------|
| T1-1 | 0.5 – 3 | Reddish brown, Silty, fine SAND (Qvop) | 27 |

**SUMMARY OF LABORATORY UNCONFINED COMPRESSIVE STRENGTH TEST RESULTS
ASTM D 1558**

| Sample No. | Depth (feet) | Geologic Unit | Hand Penetrometer Reading/Unconfined Compression Strength (tsf) and Undrained Shear Strength (ksf) |
|------------|--------------|---------------|--|
| T1-2 | -4 | Qvop | 4.5+ |
| T2-2 | -4 | Qvop | 4.5+ |
| T5-3 | -5 | Qvop | 4.5+ |
| T9-3 | -6.5 | Qvop | 4.5+ |

SAMPLE NO.: **BI-3**
 SAMPLE DEPTH (FT.): **50'**

GEOLOGIC UNIT: **Tt**

| GRAVEL | | SAND | | | SILT OR CLAY |
|--------|------|--------|--------|------|--------------|
| COARSE | FINE | COARSE | MEDIUM | FINE | |

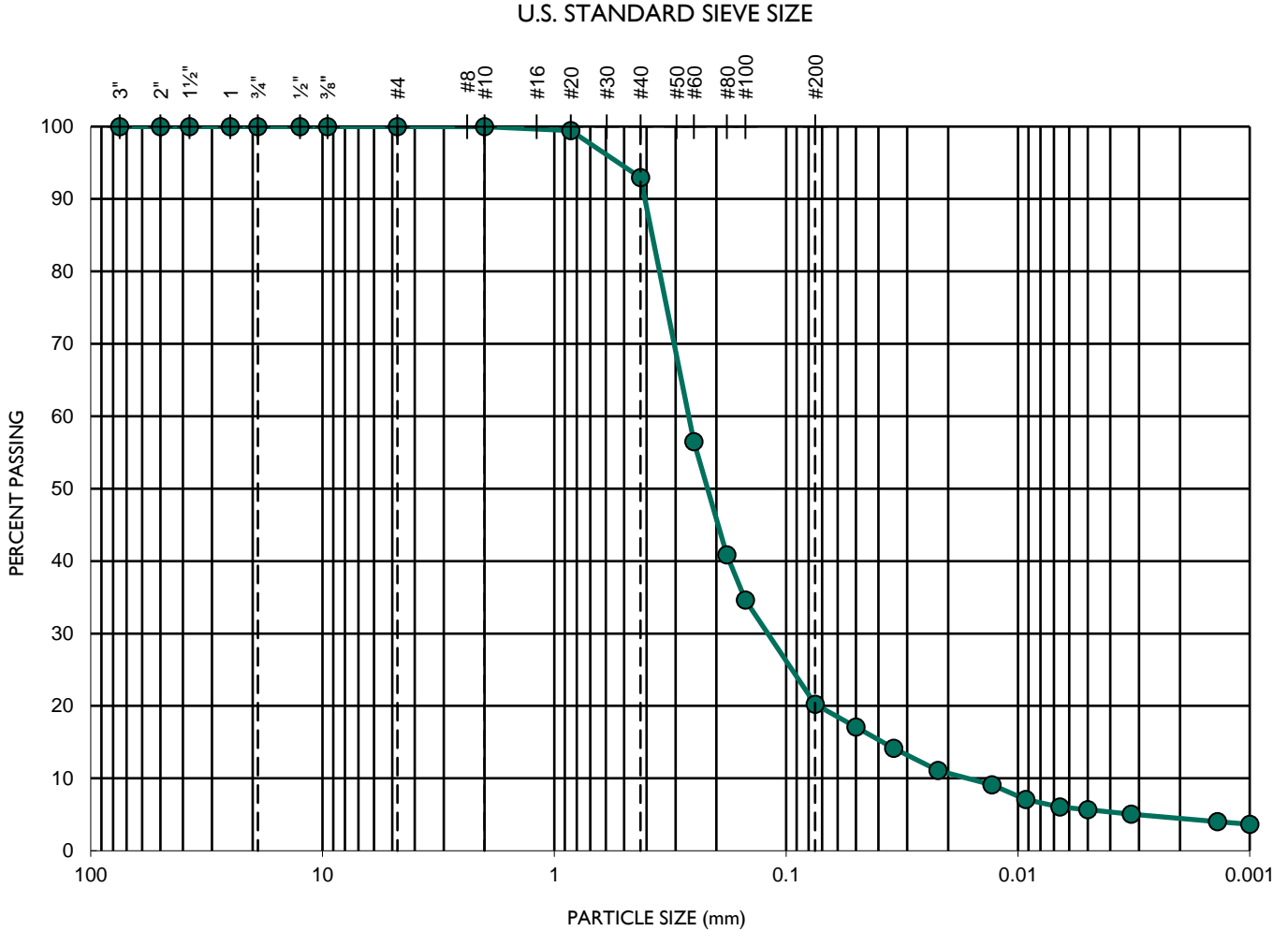

| TEST DATA | | | | | |
|----------------------|----------------------|----------------------|----------------|----------------|------------------|
| D ₁₀ (mm) | D ₃₀ (mm) | D ₆₀ (mm) | C _c | C _u | SOIL DESCRIPTION |
| 0.01710 | 0.12598 | 0.26683 | 3.5 | 15.6 | Silty SAND |

GEOCON
INCORPORATED



GEOTECHNICAL CONSULTANTS
 6960 FLANDERS DRIVE - SAN DIEGO, CALIFORNIA 92121 - 2974
 PHONE 858 558-6900 - FAX 858 558-6159

SIEVE ANALYSES - ASTM D 135 & D 422

TORREY CREST

PROJECT NO.: G2438-52-01

SAMPLE NO.: **BI-4**
 SAMPLE DEPTH (FT.): **60'**

GEOLOGIC UNIT: **Tt**

| | | | | | |
|---------------|------|-------------|--------|------|---------------------|
| GRAVEL | | SAND | | | SILT OR CLAY |
| COARSE | FINE | COARSE | MEDIUM | FINE | |

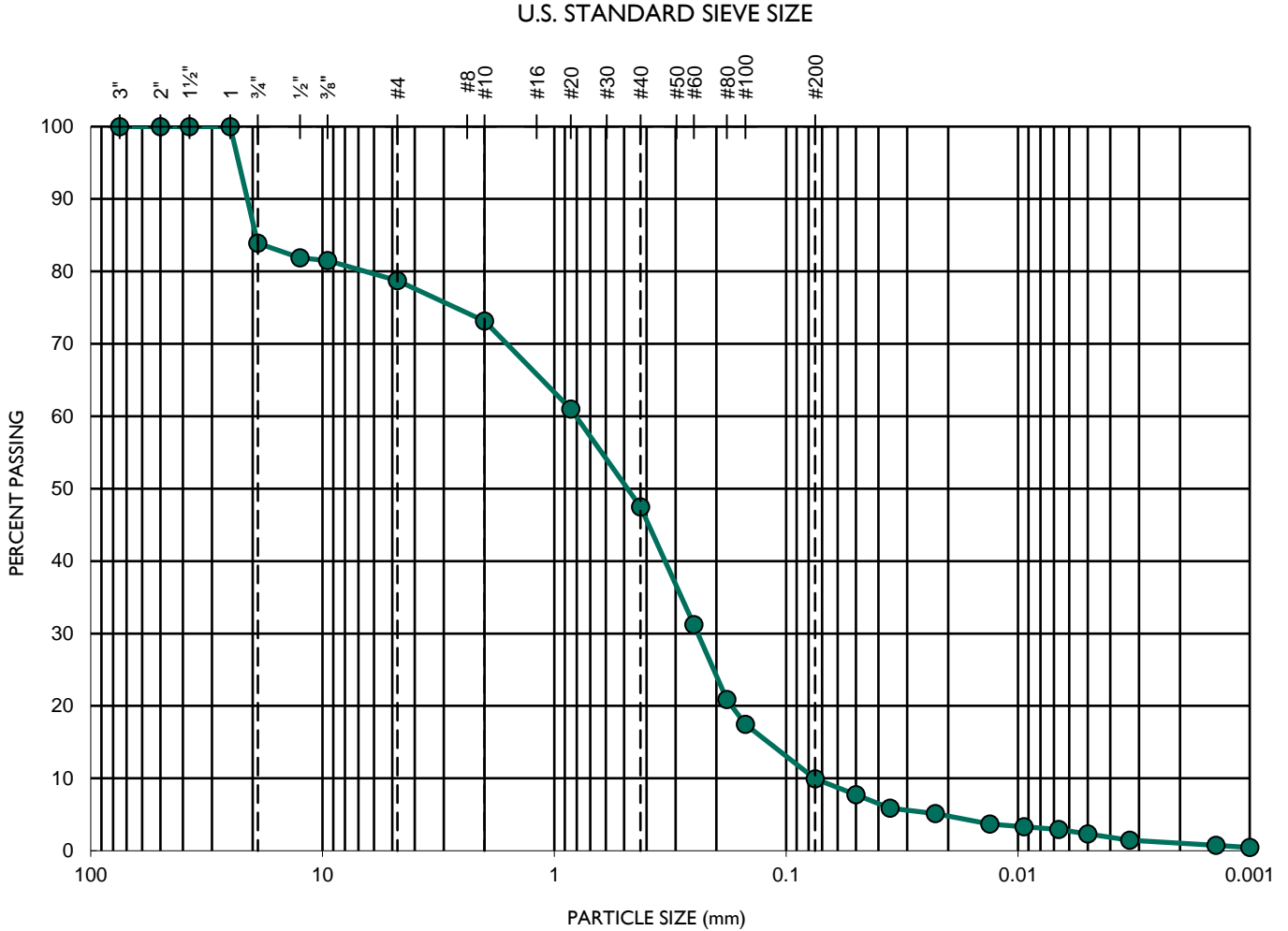

| TEST DATA | | | | | |
|----------------------|----------------------|----------------------|----------------|----------------|------------------|
| D ₁₀ (mm) | D ₃₀ (mm) | D ₆₀ (mm) | C _c | C _u | SOIL DESCRIPTION |
| 0.07561 | 0.24169 | 0.81891 | 0.9 | 10.8 | Silty SAND |

GEOCON
INCORPORATED



GEOTECHNICAL CONSULTANTS
 6960 FLANDERS DRIVE - SAN DIEGO, CALIFORNIA 92121 - 2974
 PHONE 858 558-6900 - FAX 858 558-6159

SIEVE ANALYSES - ASTM D 135 & D 422

TORREY CREST

PROJECT NO.: G2438-52-01

SAMPLE NO.: **B2-2**
 SAMPLE DEPTH (FT.): **55'**

GEOLOGIC UNIT: **Tt**

| GRAVEL | | SAND | | | SILT OR CLAY |
|--------|------|--------|--------|------|--------------|
| COARSE | FINE | COARSE | MEDIUM | FINE | |

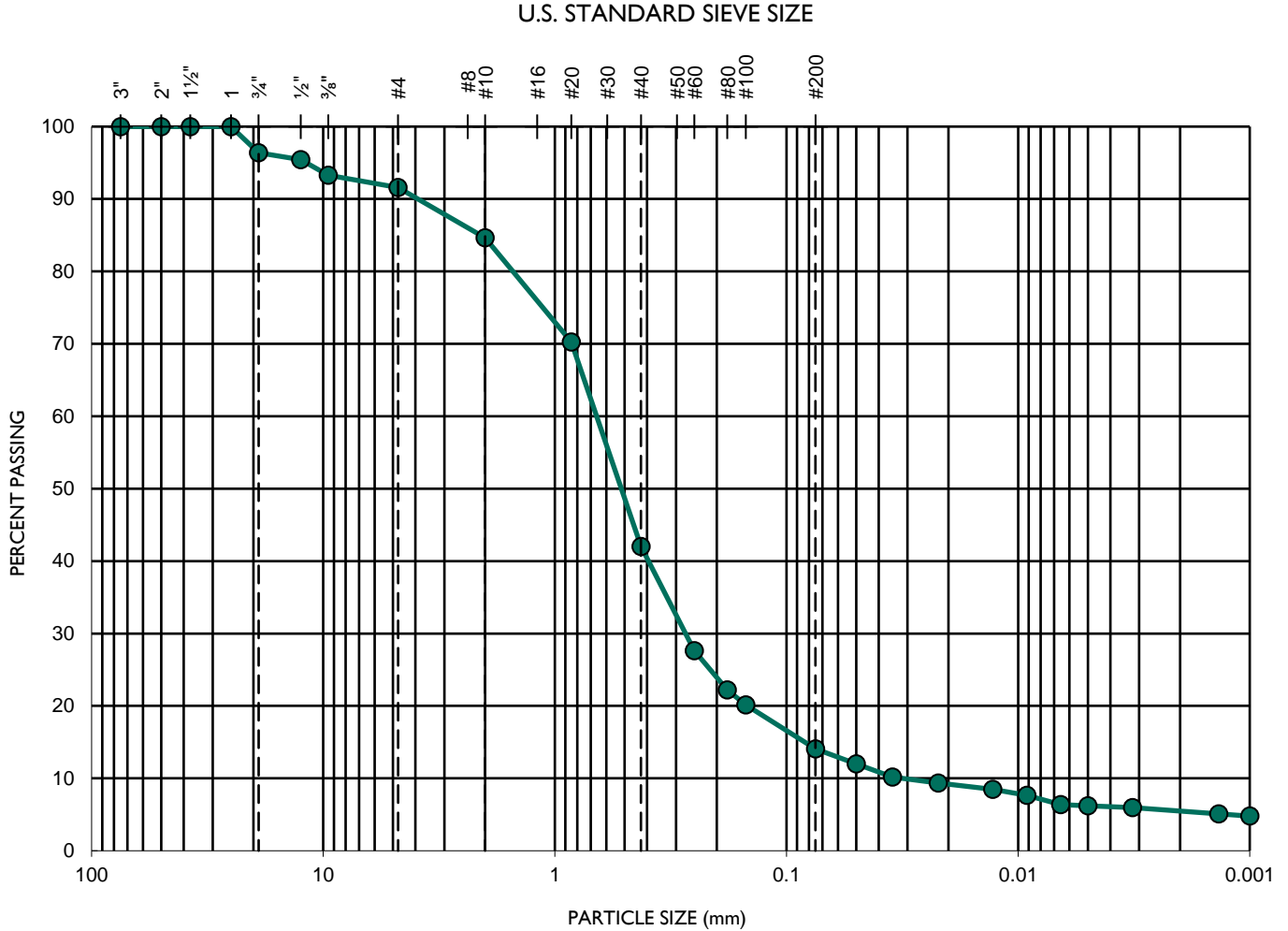

| TEST DATA | | | | | |
|----------------------|----------------------|----------------------|----------------|----------------|------------------|
| D ₁₀ (mm) | D ₃₀ (mm) | D ₆₀ (mm) | C _c | C _u | SOIL DESCRIPTION |
| 0.03203 | 0.27865 | 0.69571 | 3.5 | 21.7 | Silty SAND |

GEOCON
INCORPORATED



GEOTECHNICAL CONSULTANTS
 6960 FLANDERS DRIVE - SAN DIEGO, CALIFORNIA 92121 - 2974
 PHONE 858 558-6900 - FAX 858 558-6159

SIEVE ANALYSES - ASTM D 135 & D 422

TORREY CREST

PROJECT NO.: G2438-52-01

SAMPLE NO.: **B2-3**
 SAMPLE DEPTH (FT.): **65'**

GEOLOGIC UNIT: **Tt**

| GRAVEL | | SAND | | | SILT OR CLAY |
|--------|------|--------|--------|------|--------------|
| COARSE | FINE | COARSE | MEDIUM | FINE | |

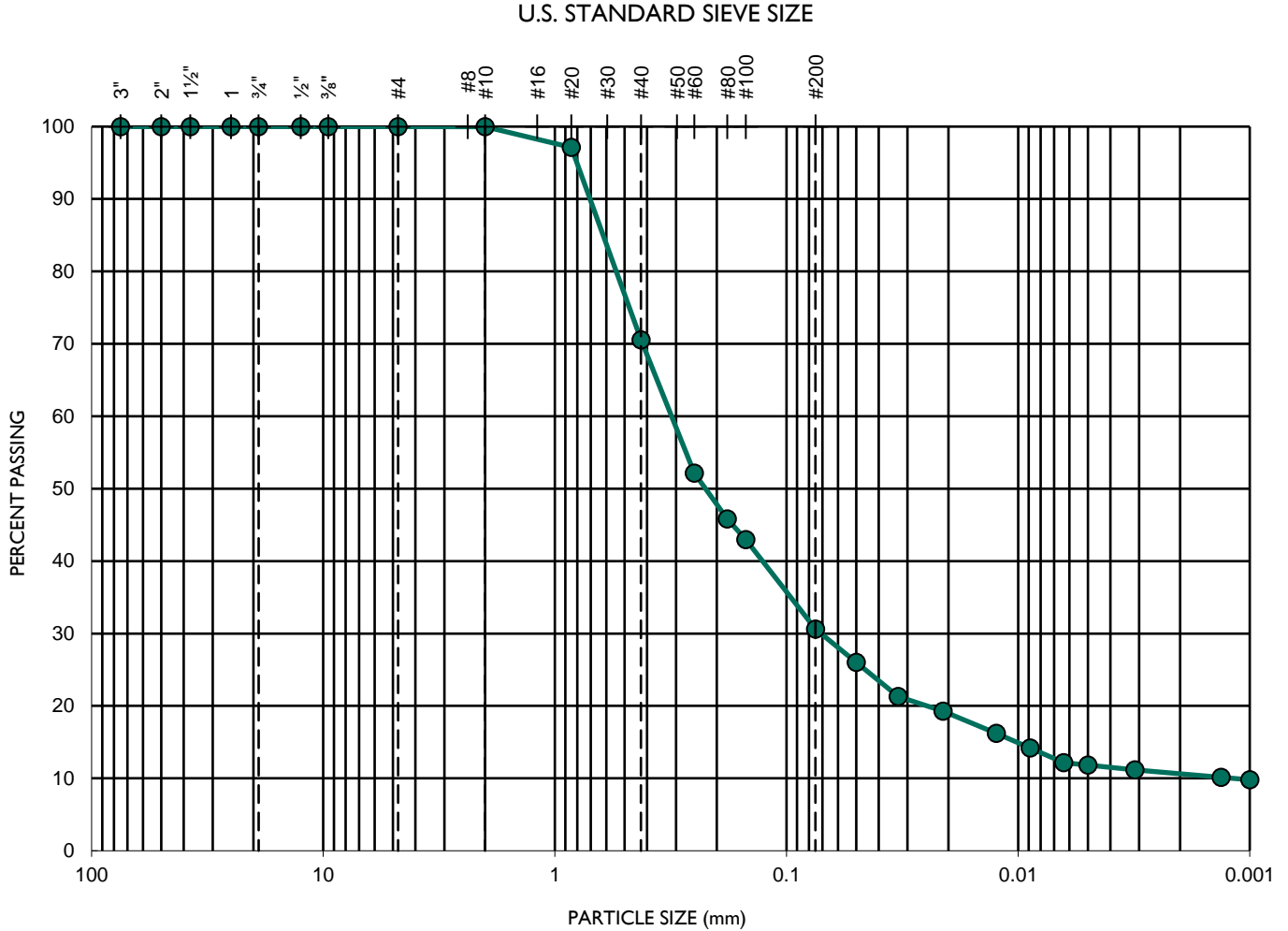

| TEST DATA | | | | | |
|----------------------|----------------------|----------------------|----------------|----------------|------------------|
| D ₁₀ (mm) | D ₃₀ (mm) | D ₆₀ (mm) | C _c | C _u | SOIL DESCRIPTION |
| 0.00119 | 0.07168 | 0.32467 | 13.3 | 272.7 | Silty SAND |

GEOCON
INCORPORATED



GEOTECHNICAL CONSULTANTS
 6960 FLANDERS DRIVE - SAN DIEGO, CALIFORNIA 92121 - 2974
 PHONE 858 558-6900 - FAX 858 558-6159

SIEVE ANALYSES - ASTM D 135 & D 422

TORREY CREST

PROJECT NO.: G2438-52-01

SAMPLE NO.: **B3-3**
 SAMPLE DEPTH (FT.): **50'**

GEOLOGIC UNIT: **Tt**

| GRAVEL | | SAND | | | SILT OR CLAY |
|--------|------|--------|--------|------|--------------|
| COARSE | FINE | COARSE | MEDIUM | FINE | |

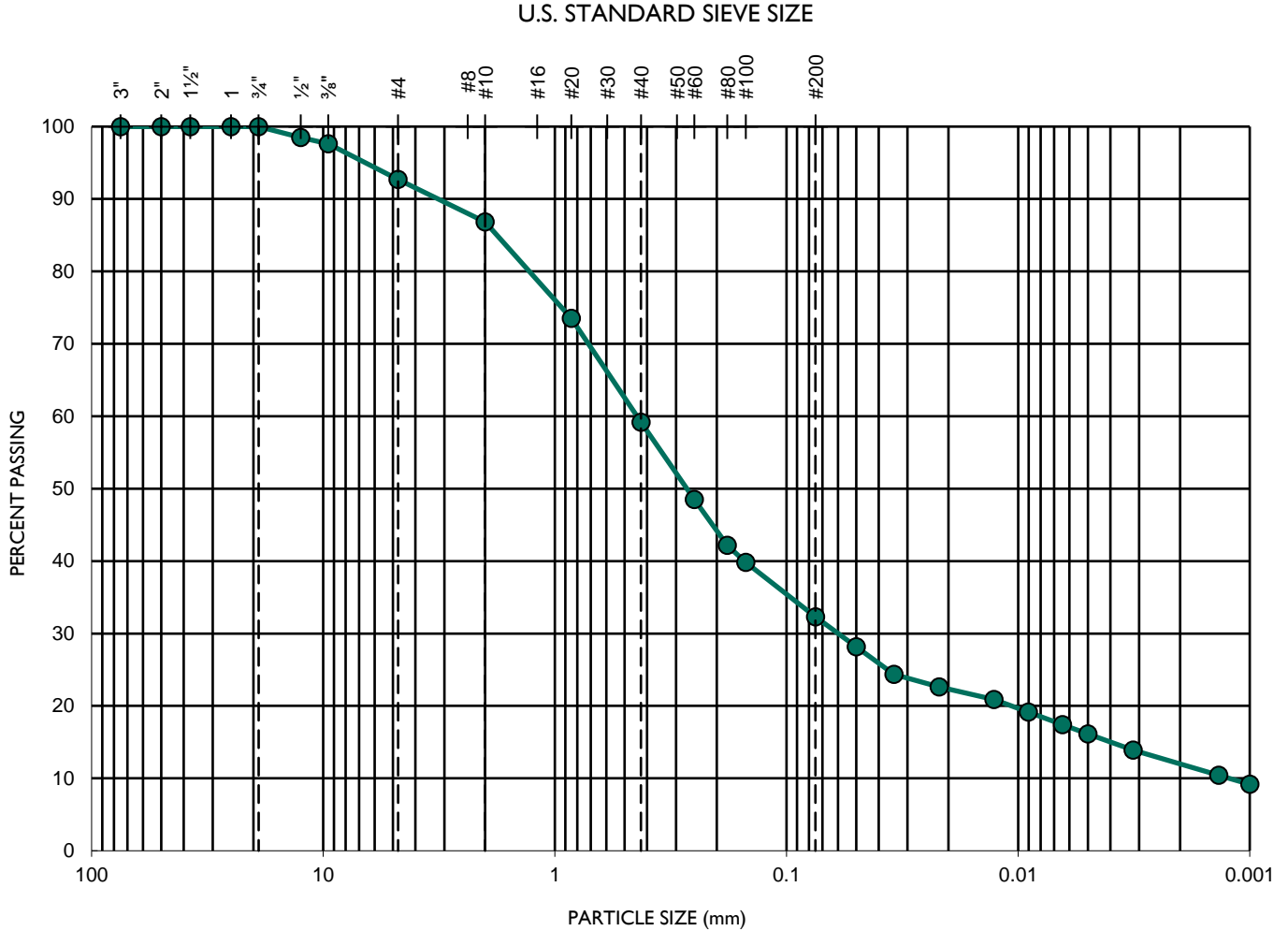

| TEST DATA | | | | | |
|----------------------|----------------------|----------------------|----------------|----------------|------------------|
| D ₁₀ (mm) | D ₃₀ (mm) | D ₆₀ (mm) | C _c | C _u | SOIL DESCRIPTION |
| 0.00124 | 0.06103 | 0.44915 | 6.7 | 363.2 | Silty SAND |

GEOCON
INCORPORATED



GEOTECHNICAL CONSULTANTS
 6960 FLANDERS DRIVE - SAN DIEGO, CALIFORNIA 92121 - 2974
 PHONE 858 558-6900 - FAX 858 558-6159

SIEVE ANALYSES - ASTM D 135 & D 422

TORREY CREST

PROJECT NO.: G2438-52-01

SAMPLE NO.: **B3-4**
 SAMPLE DEPTH (FT.): **60'**

GEOLOGIC UNIT: **Tt**

| GRAVEL | | SAND | | | SILT OR CLAY |
|--------|------|--------|--------|------|--------------|
| COARSE | FINE | COARSE | MEDIUM | FINE | |

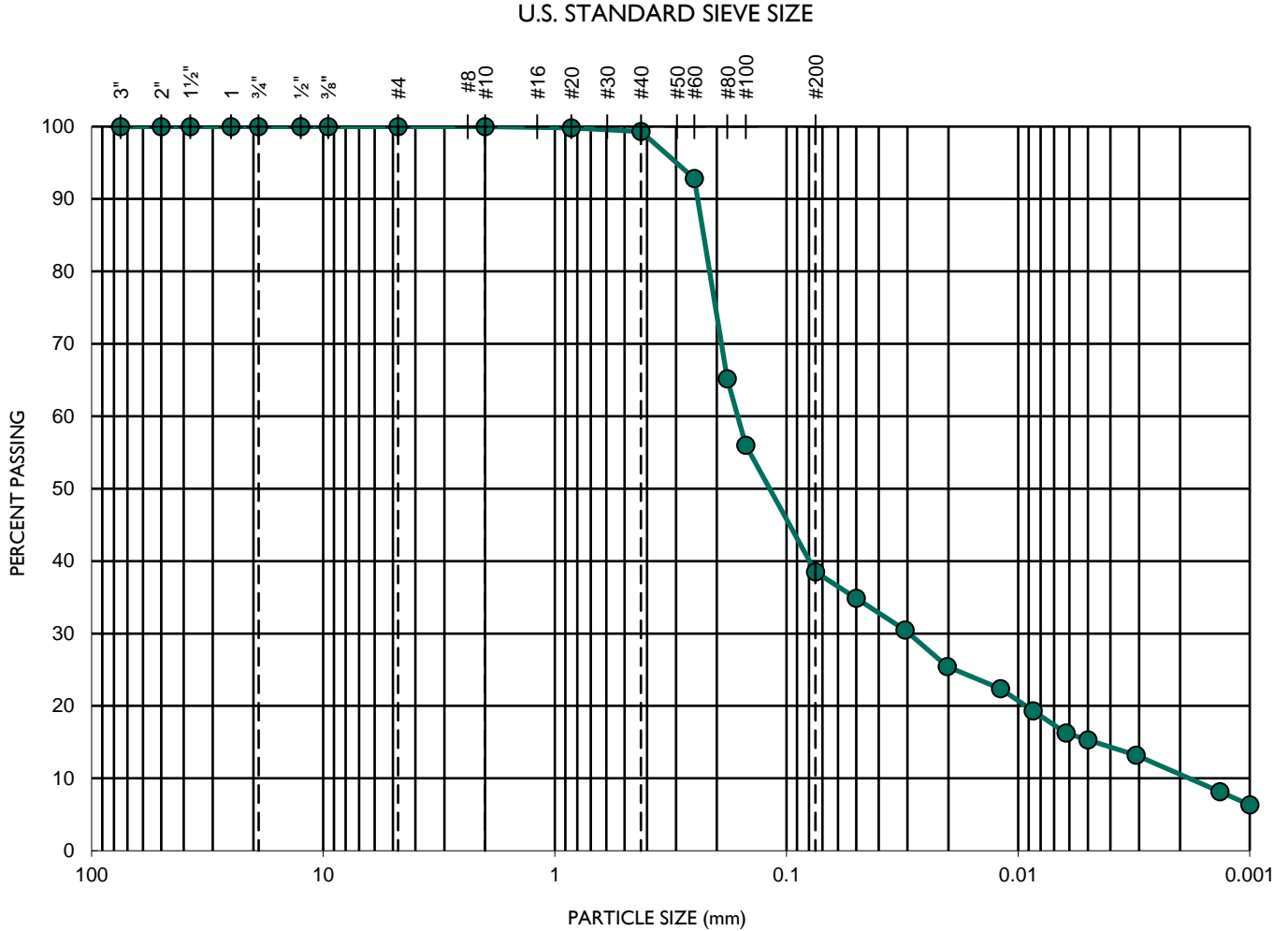

| TEST DATA | | | | | |
|----------------------|----------------------|----------------------|----------------|----------------|------------------|
| D ₁₀ (mm) | D ₃₀ (mm) | D ₆₀ (mm) | C _c | C _u | SOIL DESCRIPTION |
| 0.00199 | 0.02977 | 0.16306 | 2.7 | 82.1 | Silty SAND |

GEOCON
INCORPORATED



GEOTECHNICAL CONSULTANTS
 6960 FLANDERS DRIVE - SAN DIEGO, CALIFORNIA 92121 - 2974
 PHONE 858 558-6900 - FAX 858 558-6159

SIEVE ANALYSES - ASTM D 135 & D 422

TORREY CREST

PROJECT NO.: G2438-52-01

SAMPLE NO.: **B4-1**
 SAMPLE DEPTH (FT.): **50'**

GEOLOGIC UNIT: **Tt**

| | | | | | |
|---------------|------|-------------|--------|------|---------------------|
| GRAVEL | | SAND | | | SILT OR CLAY |
| COARSE | FINE | COARSE | MEDIUM | FINE | |

U.S. STANDARD SIEVE SIZE

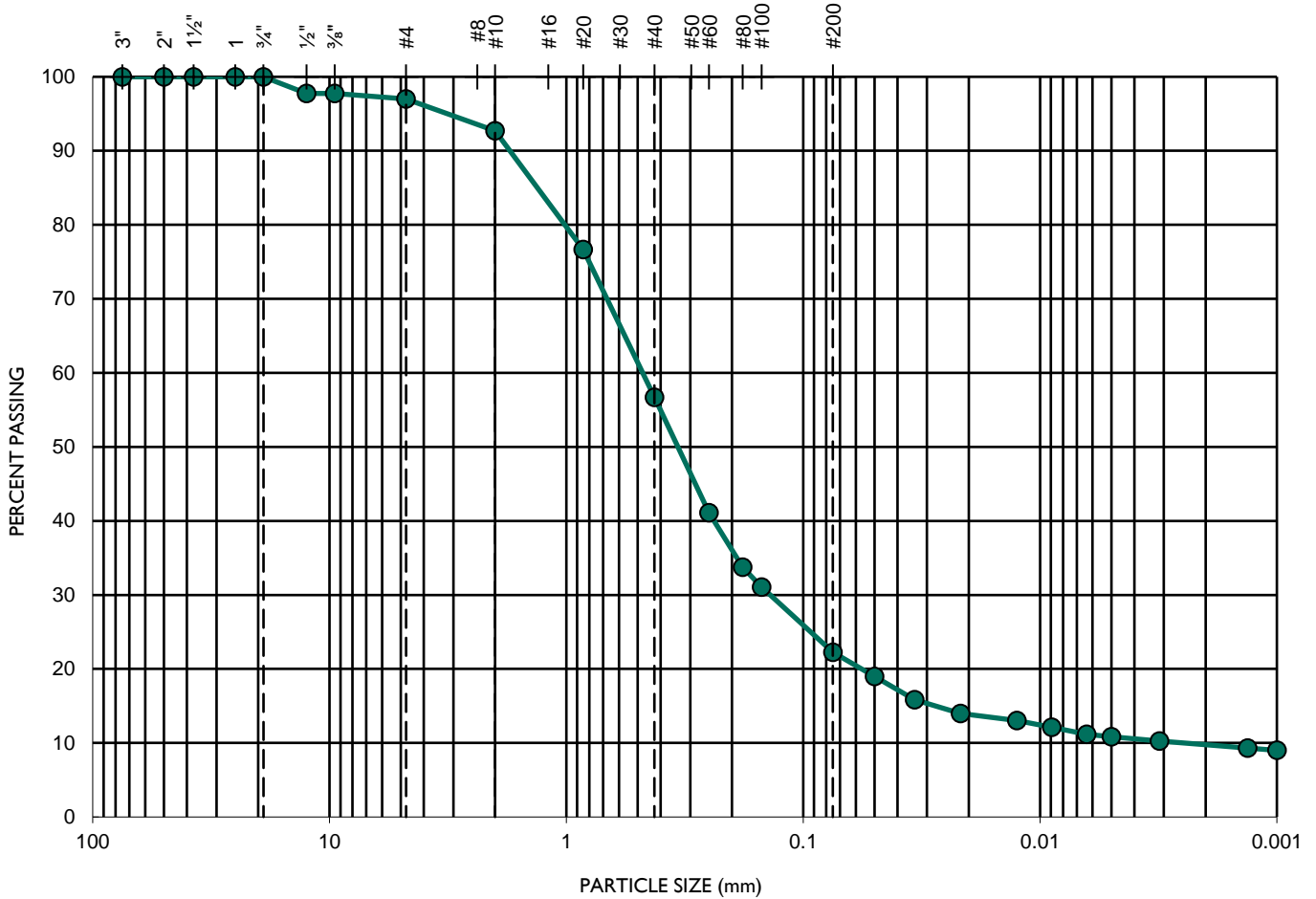

| TEST DATA | | | | | |
|----------------------|----------------------|----------------------|----------------|----------------|------------------|
| D ₁₀ (mm) | D ₃₀ (mm) | D ₆₀ (mm) | C _c | C _u | SOIL DESCRIPTION |
| 0.00265 | 0.14103 | 0.49509 | 15.1 | 186.5 | Silty SAND |

GEOCON
INCORPORATED



GEOTECHNICAL CONSULTANTS
 6960 FLANDERS DRIVE - SAN DIEGO, CALIFORNIA 92121-2974
 PHONE 858 558-6900 - FAX 858 558-6159

SIEVE ANALYSES - ASTM D 135 & D 422

TORREY CREST

PROJECT NO.: G2438-52-01

SAMPLE NO.: **B4-2**
 SAMPLE DEPTH (FT.): **60'**

GEOLOGIC UNIT: **Tt**

| GRAVEL | | SAND | | | SILT OR CLAY |
|--------|------|--------|--------|------|--------------|
| COARSE | FINE | COARSE | MEDIUM | FINE | |

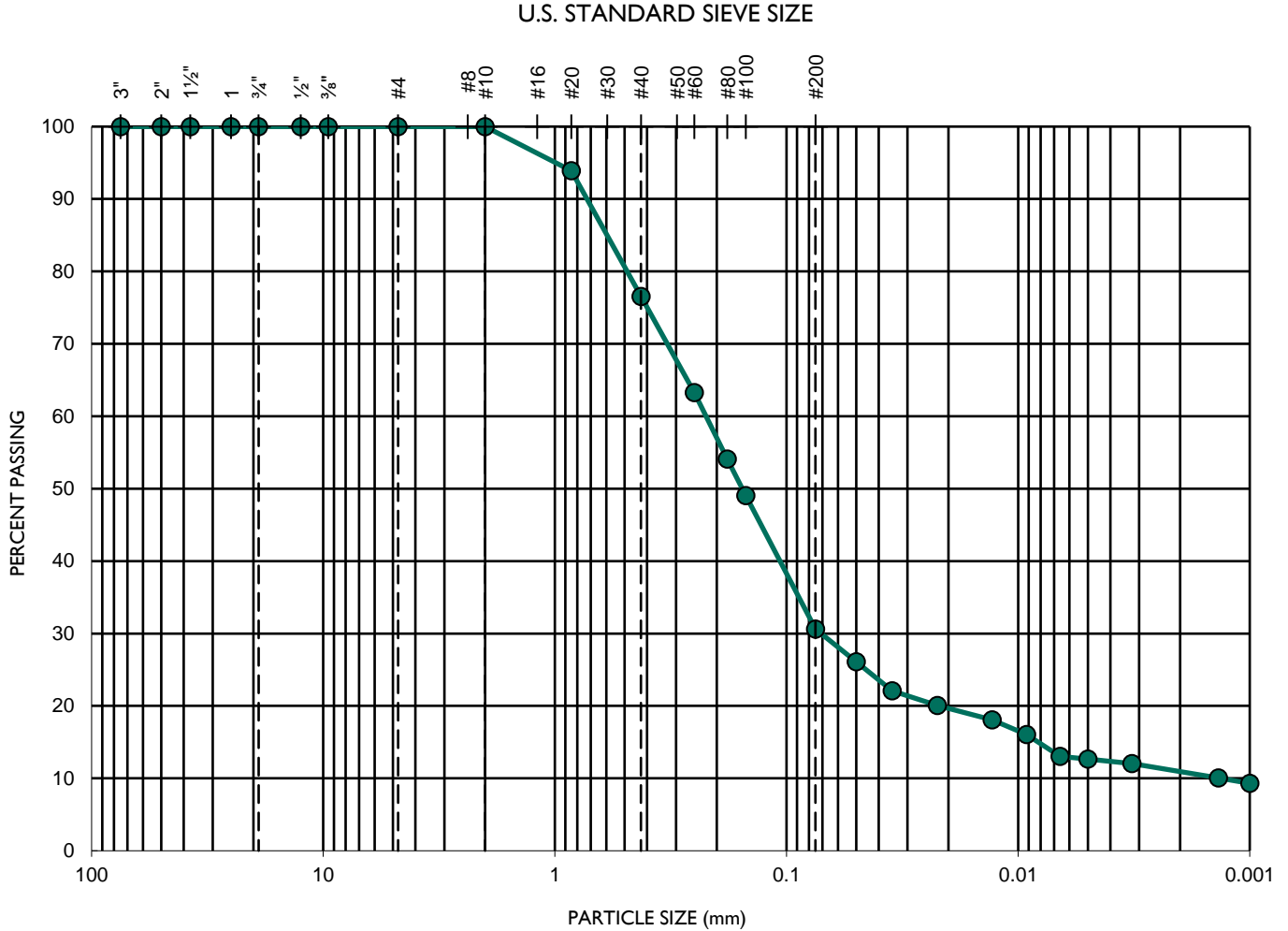

| TEST DATA | | | | | |
|----------------------|----------------------|----------------------|----------------|----------------|------------------|
| D ₁₀ (mm) | D ₃₀ (mm) | D ₆₀ (mm) | C _c | C _u | SOIL DESCRIPTION |
| 0.00135 | 0.07160 | 0.22497 | 16.9 | 167.0 | Silty SAND |

GEOCON
INCORPORATED



GEOTECHNICAL CONSULTANTS
 6960 FLANDERS DRIVE - SAN DIEGO, CALIFORNIA 92121 - 2974
 PHONE 858 558-6900 - FAX 858 558-6159

SIEVE ANALYSES - ASTM D 135 & D 422

TORREY CREST

PROJECT NO.: G2438-52-01

APPENDIX

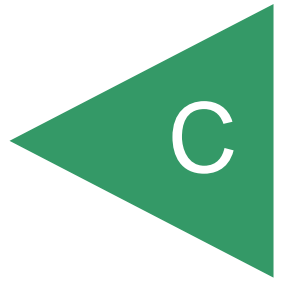

APPENDIX C

RECOMMENDED GRADING SPECIFICATIONS

FOR

**TORREY CREST
1220-1240 MELBA ROAD AND 1190 ISLAND VIEW LANE
ENCINITAS, CALIFORNIA**

PROJECT NO. G2438-52-01

RECOMMENDED GRADING SPECIFICATIONS

1. GENERAL

- 1.1 These Recommended Grading Specifications shall be used in conjunction with the Geotechnical Report for the project prepared by Geocon. The recommendations contained in the text of the Geotechnical Report are a part of the earthwork and grading specifications and shall supersede the provisions contained hereinafter in the case of conflict.
- 1.2 Prior to the commencement of grading, a geotechnical consultant (Consultant) shall be employed for the purpose of observing earthwork procedures and testing the fills for substantial conformance with the recommendations of the Geotechnical Report and these specifications. The Consultant should provide adequate testing and observation services so that they may assess whether, in their opinion, the work was performed in substantial conformance with these specifications. It shall be the responsibility of the Contractor to assist the Consultant and keep them apprised of work schedules and changes so that personnel may be scheduled accordingly.
- 1.3 It shall be the sole responsibility of the Contractor to provide adequate equipment and methods to accomplish the work in accordance with applicable grading codes or agency ordinances, these specifications and the approved grading plans. If, in the opinion of the Consultant, unsatisfactory conditions such as questionable soil materials, poor moisture condition, inadequate compaction, and/or adverse weather result in a quality of work not in conformance with these specifications, the Consultant will be empowered to reject the work and recommend to the Owner that grading be stopped until the unacceptable conditions are corrected.

2. DEFINITIONS

- 2.1 **Owner** shall refer to the owner of the property or the entity on whose behalf the grading work is being performed and who has contracted with the Contractor to have grading performed.
- 2.2 **Contractor** shall refer to the Contractor performing the site grading work.
- 2.3 **Civil Engineer** or **Engineer of Work** shall refer to the California licensed Civil Engineer or consulting firm responsible for preparation of the grading plans, surveying and verifying as-graded topography.
- 2.4 **Consultant** shall refer to the soil engineering and engineering geology consulting firm retained to provide geotechnical services for the project.

- 2.5 **Soil Engineer** shall refer to a California licensed Civil Engineer retained by the Owner, who is experienced in the practice of geotechnical engineering. The Soil Engineer shall be responsible for having qualified representatives on-site to observe and test the Contractor's work for conformance with these specifications.
- 2.6 **Engineering Geologist** shall refer to a California licensed Engineering Geologist retained by the Owner to provide geologic observations and recommendations during the site grading.
- 2.7 **Geotechnical Report** shall refer to a soil report (including all addenda) which may include a geologic reconnaissance or geologic investigation that was prepared specifically for the development of the project for which these Recommended Grading Specifications are intended to apply.

3. MATERIALS

- 3.1 Materials for compacted fill shall consist of any soil excavated from the cut areas or imported to the site that, in the opinion of the Consultant, is suitable for use in construction of fills. In general, fill materials can be classified as *soil* fills, *soil-rock* fills or *rock* fills, as defined below.
- 3.1.1 **Soil fills** are defined as fills containing no rocks or hard lumps greater than 12 inches in maximum dimension and containing at least 40 percent by weight of material smaller than $\frac{3}{4}$ inch in size.
- 3.1.2 **Soil-rock fills** are defined as fills containing no rocks or hard lumps larger than 4 feet in maximum dimension and containing a sufficient matrix of soil fill to allow for proper compaction of soil fill around the rock fragments or hard lumps as specified in Paragraph 6.2. **Oversize rock** is defined as material greater than 12 inches.
- 3.1.3 **Rock fills** are defined as fills containing no rocks or hard lumps larger than 3 feet in maximum dimension and containing little or no fines. Fines are defined as material smaller than $\frac{3}{4}$ inch in maximum dimension. The quantity of fines shall be less than approximately 20 percent of the rock fill quantity.
- 3.2 Material of a perishable, spongy, or otherwise unsuitable nature as determined by the Consultant shall not be used in fills.
- 3.3 Materials used for fill, either imported or on-site, shall not contain hazardous materials as defined by the California Code of Regulations, Title 22, Division 4, Chapter 30, Articles 9

and 10; 40CFR; and any other applicable local, state or federal laws. The Consultant shall not be responsible for the identification or analysis of the potential presence of hazardous materials. However, if observations, odors or soil discoloration cause Consultant to suspect the presence of hazardous materials, the Consultant may request from the Owner the termination of grading operations within the affected area. Prior to resuming grading operations, the Owner shall provide a written report to the Consultant indicating that the suspected materials are not hazardous as defined by applicable laws and regulations.

- 3.4 The outer 15 feet of *soil-rock* fill slopes, measured horizontally, should be composed of properly compacted *soil* fill materials approved by the Consultant. *Rock* fill may extend to the slope face, provided that the slope is not steeper than 2:1 (horizontal:vertical) and a soil layer no thicker than 12 inches is track-walked onto the face for landscaping purposes. This procedure may be utilized provided it is acceptable to the governing agency, Owner and Consultant.
- 3.5 Samples of soil materials to be used for fill should be tested in the laboratory by the Consultant to determine the maximum density, optimum moisture content, and, where appropriate, shear strength, expansion, and gradation characteristics of the soil.
- 3.6 During grading, soil or groundwater conditions other than those identified in the Geotechnical Report may be encountered by the Contractor. The Consultant shall be notified immediately to evaluate the significance of the unanticipated condition.

4. CLEARING AND PREPARING AREAS TO BE FILLED

- 4.1 Areas to be excavated and filled shall be cleared and grubbed. Clearing shall consist of complete removal above the ground surface of trees, stumps, brush, vegetation, man-made structures, and similar debris. Grubbing shall consist of removal of stumps, roots, buried logs and other unsuitable material and shall be performed in areas to be graded. Roots and other projections exceeding 1½ inches in diameter shall be removed to a depth of 3 feet below the surface of the ground. Borrow areas shall be grubbed to the extent necessary to provide suitable fill materials.
- 4.2 Asphalt pavement material removed during clearing operations should be properly disposed at an approved off-site facility or in an acceptable area of the project evaluated by Geocon and the property owner. Concrete fragments that are free of reinforcing steel may be placed in fills, provided they are placed in accordance with Section 6.2 or 6.3 of this document.

- 4.3 After clearing and grubbing of organic matter and other unsuitable material, loose or porous soils shall be removed to the depth recommended in the Geotechnical Report. The depth of removal and compaction should be observed and approved by a representative of the Consultant. The exposed surface shall then be plowed or scarified to a minimum depth of 6 inches and until the surface is free from uneven features that would tend to prevent uniform compaction by the equipment to be used.
- 4.4 Where the slope ratio of the original ground is steeper than 5:1 (horizontal:vertical), or where recommended by the Consultant, the original ground should be benched in accordance with the following illustration.

TYPICAL BENCHING DETAIL

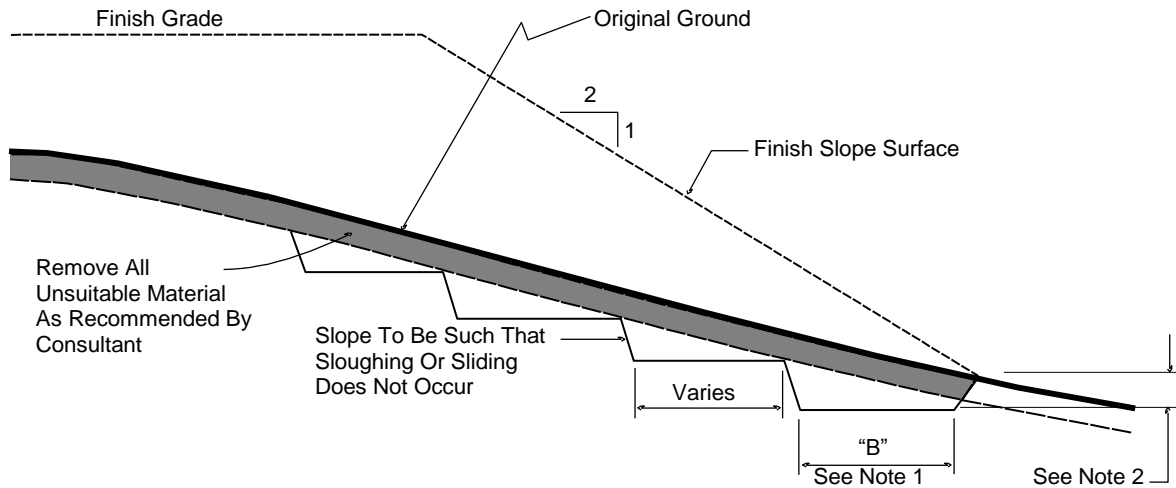

No Scale

- DETAIL NOTES: (1) Key width "B" should be a minimum of 10 feet, or sufficiently wide to permit complete coverage with the compaction equipment used. The base of the key should be graded horizontal, or inclined slightly into the natural slope.
- (2) The outside of the key should be below the topsoil or unsuitable surficial material and at least 2 feet into dense formational material. Where hard rock is exposed in the bottom of the key, the depth and configuration of the key may be modified as approved by the Consultant.

- 4.5 After areas to receive fill have been cleared and scarified, the surface should be moisture conditioned to achieve the proper moisture content, and compacted as recommended in Section 6 of these specifications.

5. COMPACTION EQUIPMENT

- 5.1 Compaction of *soil* or *soil-rock* fill shall be accomplished by sheepsfoot or segmented-steel wheeled rollers, vibratory rollers, multiple-wheel pneumatic-tired rollers, or other types of acceptable compaction equipment. Equipment shall be of such a design that it will be capable of compacting the *soil* or *soil-rock* fill to the specified relative compaction at the specified moisture content.
- 5.2 Compaction of *rock* fills shall be performed in accordance with Section 6.3.

6. PLACING, SPREADING AND COMPACTION OF FILL MATERIAL

- 6.1 *Soil* fill, as defined in Paragraph 3.1.1, shall be placed by the Contractor in accordance with the following recommendations:
- 6.1.1 *Soil* fill shall be placed by the Contractor in layers that, when compacted, should generally not exceed 8 inches. Each layer shall be spread evenly and shall be thoroughly mixed during spreading to obtain uniformity of material and moisture in each layer. The entire fill shall be constructed as a unit in nearly level lifts. Rock materials greater than 12 inches in maximum dimension shall be placed in accordance with Section 6.2 or 6.3 of these specifications.
- 6.1.2 In general, the *soil* fill shall be compacted at a moisture content at or above the optimum moisture content as determined by ASTM D 1557.
- 6.1.3 When the moisture content of *soil* fill is below that specified by the Consultant, water shall be added by the Contractor until the moisture content is in the range specified.
- 6.1.4 When the moisture content of the *soil* fill is above the range specified by the Consultant or too wet to achieve proper compaction, the *soil* fill shall be aerated by the Contractor by blading/mixing, or other satisfactory methods until the moisture content is within the range specified.
- 6.1.5 After each layer has been placed, mixed, and spread evenly, it shall be thoroughly compacted by the Contractor to a relative compaction of at least 90 percent. Relative compaction is defined as the ratio (expressed in percent) of the in-place dry density of the compacted fill to the maximum laboratory dry density as determined in accordance with ASTM D 1557. Compaction shall be continuous over the entire area, and compaction equipment shall make sufficient passes so that the specified minimum relative compaction has been achieved throughout the entire fill.

- 6.1.6 Where practical, soils having an Expansion Index greater than 50 should be placed at least 3 feet below finish pad grade and should be compacted at a moisture content generally 2 to 4 percent greater than the optimum moisture content for the material.
 - 6.1.7 Properly compacted *soil* fill shall extend to the design surface of fill slopes. To achieve proper compaction, it is recommended that fill slopes be over-built by at least 3 feet and then cut to the design grade. This procedure is considered preferable to track-walking of slopes, as described in the following paragraph.
 - 6.1.8 As an alternative to over-building of slopes, slope faces may be back-rolled with a heavy-duty loaded sheepsfoot or vibratory roller at maximum 4-foot fill height intervals. Upon completion, slopes should then be track-walked with a D-8 dozer or similar equipment, such that a dozer track covers all slope surfaces at least twice.
- 6.2 *Soil-rock* fill, as defined in Paragraph 3.1.2, shall be placed by the Contractor in accordance with the following recommendations:
- 6.2.1 Rocks larger than 12 inches but less than 4 feet in maximum dimension may be incorporated into the compacted *soil* fill, but shall be limited to the area measured 15 feet minimum horizontally from the slope face and 5 feet below finish grade or 3 feet below the deepest utility, whichever is deeper.
 - 6.2.2 Rocks or rock fragments up to 4 feet in maximum dimension may either be individually placed or placed in windrows. Under certain conditions, rocks or rock fragments up to 10 feet in maximum dimension may be placed using similar methods. The acceptability of placing rock materials greater than 4 feet in maximum dimension shall be evaluated during grading as specific cases arise and shall be approved by the Consultant prior to placement.
 - 6.2.3 For individual placement, sufficient space shall be provided between rocks to allow for passage of compaction equipment.
 - 6.2.4 For windrow placement, the rocks should be placed in trenches excavated in properly compacted *soil* fill. Trenches should be approximately 5 feet wide and 4 feet deep in maximum dimension. The voids around and beneath rocks should be filled with approved granular soil having a Sand Equivalent of 30 or greater and should be compacted by flooding. Windrows may also be placed utilizing an "open-face" method in lieu of the trench procedure, however, this method should first be approved by the Consultant.

- 6.2.5 Windrows should generally be parallel to each other and may be placed either parallel to or perpendicular to the face of the slope depending on the site geometry. The minimum horizontal spacing for windrows shall be 12 feet center-to-center with a 5-foot stagger or offset from lower courses to next overlying course. The minimum vertical spacing between windrow courses shall be 2 feet from the top of a lower windrow to the bottom of the next higher windrow.
- 6.2.6 Rock placement, fill placement and flooding of approved granular soil in the windrows should be continuously observed by the Consultant.
- 6.3 *Rock* fills, as defined in Section 3.1.3, shall be placed by the Contractor in accordance with the following recommendations:
- 6.3.1 The base of the *rock* fill shall be placed on a sloping surface (minimum slope of 2 percent). The surface shall slope toward suitable subdrainage outlet facilities. The *rock* fills shall be provided with subdrains during construction so that a hydrostatic pressure buildup does not develop. The subdrains shall be permanently connected to controlled drainage facilities to control post-construction infiltration of water.
- 6.3.2 *Rock* fills shall be placed in lifts not exceeding 3 feet. Placement shall be by rock trucks traversing previously placed lifts and dumping at the edge of the currently placed lift. Spreading of the *rock* fill shall be by dozer to facilitate *seating* of the rock. The *rock* fill shall be watered heavily during placement. Watering shall consist of water trucks traversing in front of the current rock lift face and spraying water continuously during rock placement. Compaction equipment with compactive energy comparable to or greater than that of a 20-ton steel vibratory roller or other compaction equipment providing suitable energy to achieve the required compaction or deflection as recommended in Paragraph 6.3.3 shall be utilized. The number of passes to be made should be determined as described in Paragraph 6.3.3. Once a *rock* fill lift has been covered with *soil* fill, no additional *rock* fill lifts will be permitted over the *soil* fill.
- 6.3.3 Plate bearing tests, in accordance with ASTM D 1196, may be performed in both the compacted *soil* fill and in the *rock* fill to aid in determining the required minimum number of passes of the compaction equipment. If performed, a minimum of three plate bearing tests should be performed in the properly compacted *soil* fill (minimum relative compaction of 90 percent). Plate bearing tests shall then be performed on areas of *rock* fill having two passes, four passes and six passes of the compaction equipment, respectively. The number of passes required for the *rock* fill shall be determined by comparing the results of the plate bearing tests for the *soil* fill and the *rock* fill and by evaluating the deflection

variation with number of passes. The required number of passes of the compaction equipment will be performed as necessary until the plate bearing deflections are equal to or less than that determined for the properly compacted *soil* fill. In no case will the required number of passes be less than two.

- 6.3.4 A representative of the Consultant should be present during *rock* fill operations to observe that the minimum number of “passes” have been obtained, that water is being properly applied and that specified procedures are being followed. The actual number of plate bearing tests will be determined by the Consultant during grading.
- 6.3.5 Test pits shall be excavated by the Contractor so that the Consultant can state that, in their opinion, sufficient water is present and that voids between large rocks are properly filled with smaller rock material. In-place density testing will not be required in the *rock* fills.
- 6.3.6 To reduce the potential for “piping” of fines into the *rock* fill from overlying *soil* fill material, a 2-foot layer of graded filter material shall be placed above the uppermost lift of *rock* fill. The need to place graded filter material below the *rock* should be determined by the Consultant prior to commencing grading. The gradation of the graded filter material will be determined at the time the *rock* fill is being excavated. Materials typical of the *rock* fill should be submitted to the Consultant in a timely manner, to allow design of the graded filter prior to the commencement of *rock* fill placement.
- 6.3.7 *Rock* fill placement should be continuously observed during placement by the Consultant.

7. SUBDRAINS

- 7.1 The geologic units on the site may have permeability characteristics and/or fracture systems that could be susceptible under certain conditions to seepage. The use of canyon subdrains may be necessary to mitigate the potential for adverse impacts associated with seepage conditions. Canyon subdrains with lengths in excess of 500 feet or extensions of existing offsite subdrains should use 8-inch-diameter pipes. Canyon subdrains less than 500 feet in length should use 6-inch-diameter pipes.

TYPICAL CANYON DRAIN DETAIL

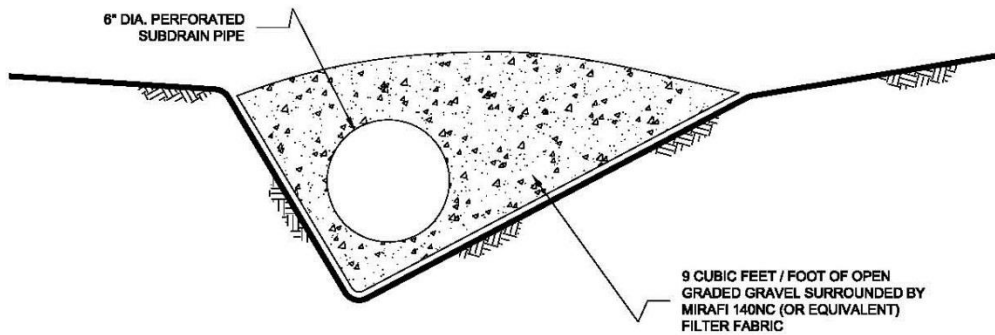
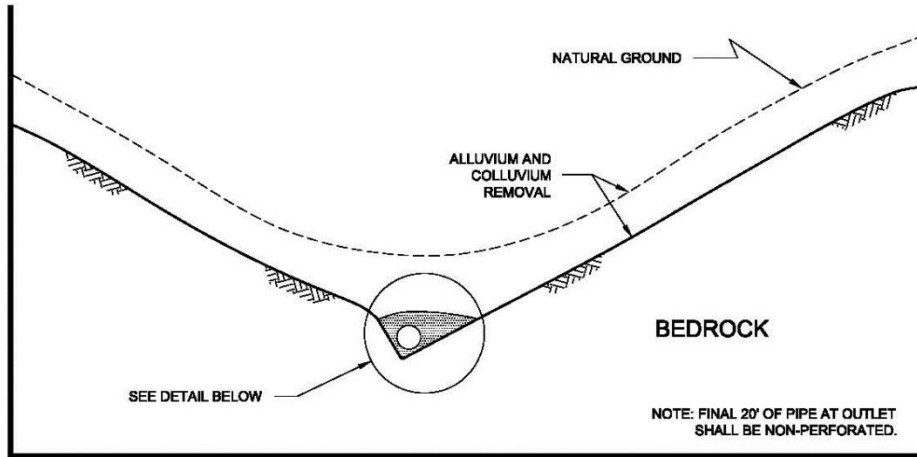

NOTES:

- 1.....8-INCH DIAMETER, SCHEDULE 80 PVC PERFORATED PIPE FOR FILLS IN EXCESS OF 100-FEET IN DEPTH OR A PIPE LENGTH OF LONGER THAN 500 FEET.
- 2.....6-INCH DIAMETER, SCHEDULE 40 PVC PERFORATED PIPE FOR FILLS LESS THAN 100-FEET IN DEPTH OR A PIPE LENGTH SHORTER THAN 500 FEET.

NO SCALE

7.2 Slope drains within stability fill keyways should use 4-inch-diameter (or larger) pipes.

TYPICAL STABILITY FILL DETAIL

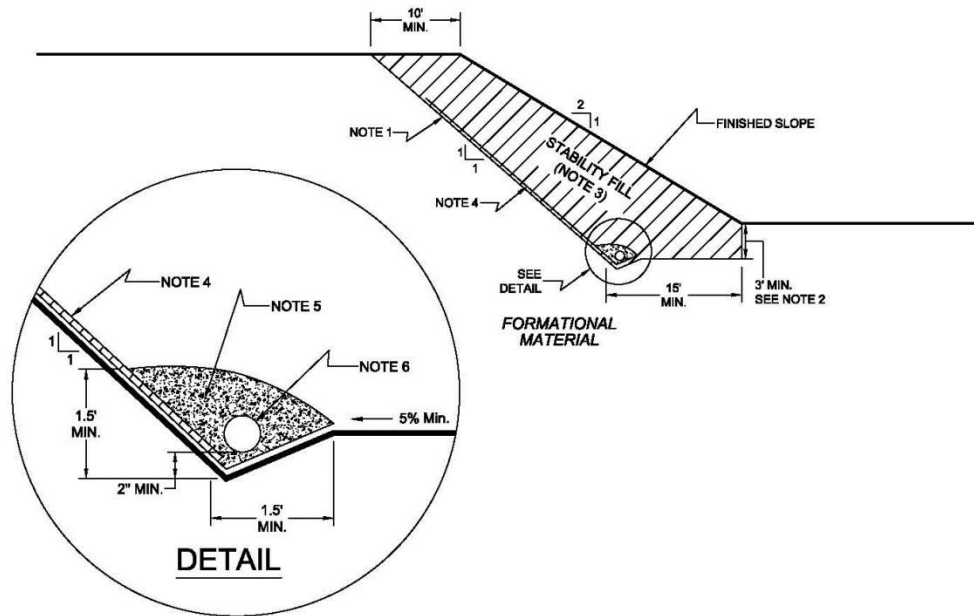

NOTES:

- 1.....EXCAVATE BACKCUT AT 1:1 INCLINATION (UNLESS OTHERWISE NOTED).
- 2.....BASE OF STABILITY FILL TO BE 3 FEET INTO FORMATIONAL MATERIAL, SLOPING A MINIMUM 5% INTO SLOPE.
- 3.....STABILITY FILL TO BE COMPOSED OF PROPERLY COMPACTED GRANULAR SOIL.
- 4.....CHIMNEY DRAINS TO BE APPROVED PREFABRICATED CHIMNEY DRAIN PANELS (MIRADRAIN G200N OR EQUIVALENT) SPACED APPROXIMATELY 20 FEET CENTER TO CENTER AND 4 FEET WIDE. CLOSER SPACING MAY BE REQUIRED IF SEEPAGE IS ENCOUNTERED.
- 5.....FILTER MATERIAL TO BE 3/4-INCH, OPEN-GRADED CRUSHED ROCK ENCLOSED IN APPROVED FILTER FABRIC (MIRAFI 140NC).
- 6.....COLLECTOR PIPE TO BE 4-INCH MINIMUM DIAMETER, PERFORATED, THICK-WALLED PVC SCHEDULE 40 OR EQUIVALENT, AND SLOPED TO DRAIN AT 1 PERCENT MINIMUM TO APPROVED OUTLET.

NO SCALE

7.3 The actual subdrain locations will be evaluated in the field during the remedial grading operations. Additional drains may be necessary depending on the conditions observed and the requirements of the local regulatory agencies. Appropriate subdrain outlets should be evaluated prior to finalizing 40-scale grading plans.

7.4 *Rock fill or soil-rock fill* areas may require subdrains along their down-slope perimeters to mitigate the potential for buildup of water from construction or landscape irrigation. The subdrains should be at least 6-inch-diameter pipes encapsulated in gravel and filter fabric. *Rock fill* drains should be constructed using the same requirements as canyon subdrains.

7.5 Prior to outletting, the final 20-foot segment of a subdrain that will not be extended during future development should consist of non-perforated drainpipe. At the non-perforated/perforated interface, a seepage cutoff wall should be constructed on the downslope side of the pipe.

TYPICAL CUT OFF WALL DETAIL

FRONT VIEW

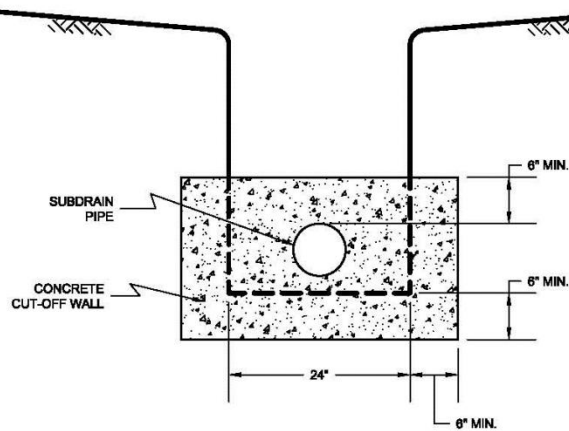

NO SCALE

SIDE VIEW

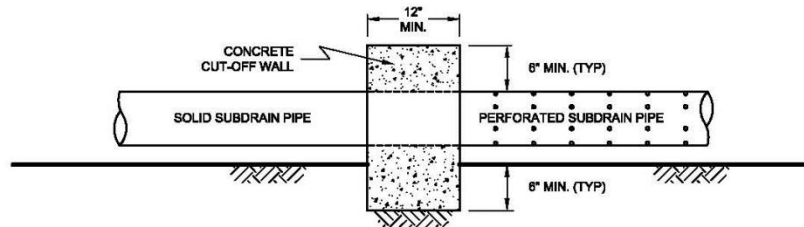

NO SCALE

7.6 Subdrains that discharge into a natural drainage course or open space area should be provided with a permanent headwall structure.

TYPICAL HEADWALL DETAIL

FRONT VIEW

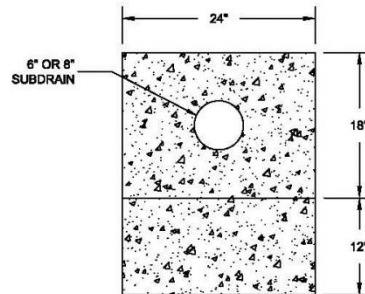

NO SCALE

SIDE VIEW

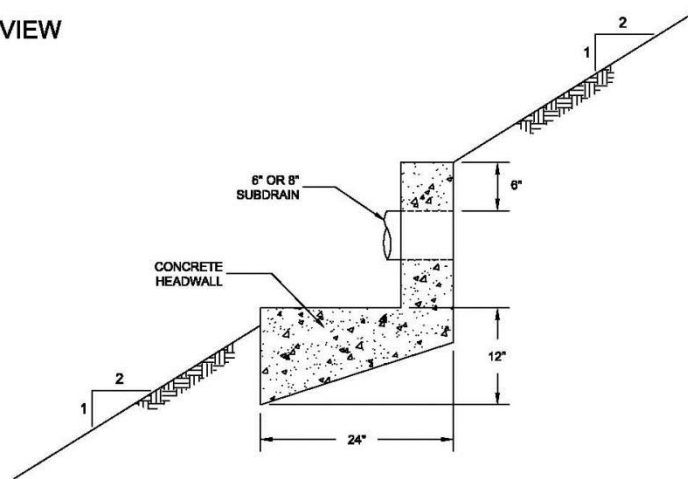

NOTE: HEADWALL SHOULD OUTLET AT TOE OF FILL SLOPE
OR INTO CONTROLLED SURFACE DRAINAGE

NO SCALE

- 7.7 The final grading plans should show the location of the proposed subdrains. After completion of remedial excavations and subdrain installation, the project civil engineer should survey the drain locations and prepare an “as-built” map showing the drain locations. The final outlet and connection locations should be determined during grading operations. Subdrains that will be extended on adjacent projects after grading can be placed on formational material and a vertical riser should be placed at the end of the subdrain. The grading contractor should consider videoing the subdrains shortly after burial to check proper installation and functionality. The contractor is responsible for the performance of the drains.

8. OBSERVATION AND TESTING

- 8.1 The Consultant shall be the Owner's representative to observe and perform tests during clearing, grubbing, filling, and compaction operations. In general, no more than 2 feet in vertical elevation of *soil* or *soil-rock* fill should be placed without at least one field density test being performed within that interval. In addition, a minimum of one field density test should be performed for every 2,000 cubic yards of *soil* or *soil-rock* fill placed and compacted.
- 8.2 The Consultant should perform a sufficient distribution of field density tests of the compacted *soil* or *soil-rock* fill to provide a basis for expressing an opinion whether the fill material is compacted as specified. Density tests shall be performed in the compacted materials below any disturbed surface. When these tests indicate that the density of any layer of fill or portion thereof is below that specified, the particular layer or areas represented by the test shall be reworked until the specified density has been achieved.
- 8.3 During placement of *rock* fill, the Consultant should observe that the minimum number of passes have been obtained per the criteria discussed in Section 6.3.3. The Consultant should request the excavation of observation pits and may perform plate bearing tests on the placed *rock* fills. The observation pits will be excavated to provide a basis for expressing an opinion as to whether the *rock* fill is properly seated and sufficient moisture has been applied to the material. When observations indicate that a layer of *rock* fill or any portion thereof is below that specified, the affected layer or area shall be reworked until the *rock* fill has been adequately seated and sufficient moisture applied.
- 8.4 A settlement monitoring program designed by the Consultant may be conducted in areas of *rock* fill placement. The specific design of the monitoring program shall be as recommended in the Conclusions and Recommendations section of the project Geotechnical Report or in the final report of testing and observation services performed during grading.
- 8.5 We should observe the placement of subdrains, to check that the drainage devices have been placed and constructed in substantial conformance with project specifications.
- 8.6 Testing procedures shall conform to the following Standards as appropriate:

8.6.1 Soil and Soil-Rock Fills:

- 8.6.1.1 Field Density Test, ASTM D 1556, *Density of Soil In-Place By the Sand-Cone Method.*

- 8.6.1.2 Field Density Test, Nuclear Method, ASTM D 6938, *Density of Soil and Soil-Aggregate In-Place by Nuclear Methods (Shallow Depth)*.
- 8.6.1.3 Laboratory Compaction Test, ASTM D 1557, *Moisture-Density Relations of Soils and Soil-Aggregate Mixtures Using 10-Pound Hammer and 18-Inch Drop*.
- 8.6.1.4. Expansion Index Test, ASTM D 4829, *Expansion Index Test*.

9. PROTECTION OF WORK

- 9.1 During construction, the Contractor shall properly grade all excavated surfaces to provide positive drainage and prevent ponding of water. Drainage of surface water shall be controlled to avoid damage to adjoining properties or to finished work on the site. The Contractor shall take remedial measures to prevent erosion of freshly graded areas until such time as permanent drainage and erosion control features have been installed. Areas subjected to erosion or sedimentation shall be properly prepared in accordance with the Specifications prior to placing additional fill or structures.
- 9.2 After completion of grading as observed and tested by the Consultant, no further excavation or filling shall be conducted except in conjunction with the services of the Consultant.

10. CERTIFICATIONS AND FINAL REPORTS

- 10.1 Upon completion of the work, Contractor shall furnish Owner a certification by the Civil Engineer stating that the lots and/or building pads are graded to within 0.1 foot vertically of elevations shown on the grading plan and that all tops and toes of slopes are within 0.5 foot horizontally of the positions shown on the grading plans. After installation of a section of subdrain, the project Civil Engineer should survey its location and prepare an *as-built* plan of the subdrain location. The project Civil Engineer should verify the proper outlet for the subdrains and the Contractor should ensure that the drain system is free of obstructions.
- 10.2 The Owner is responsible for furnishing a final as-graded soil and geologic report satisfactory to the appropriate governing or accepting agencies. The as-graded report should be prepared and signed by a California licensed Civil Engineer experienced in geotechnical engineering and by a California Certified Engineering Geologist, indicating that the geotechnical aspects of the grading were performed in substantial conformance with the Specifications or approved changes to the Specifications.

LIST OF REFERENCES

1. *2019 California Building Code, California Code of Regulations, Title 24, Part 2, based on the 2018 International Building Code*, prepared by California Building Standards Commission, dated July 2019.
2. *ACI 318-14, Building Code Requirements for Structural Concrete and Commentary on Building Code Requirements for Structural Concrete*, prepared by the American Concrete Institute, dated September 2014.
3. American Concrete Institute, *ACI 330-08, Guide for the Design and Construction of Concrete Parking Lots*, dated June 2008.
4. ASCE 7-16, *Minimum Design Loads and Associated Criteria for Buildings and Other Structures*, 2017.
5. California Department of Conservation, Division of Mines and Geology, *Probabilistic Seismic Hazard Assessment for the State of California*, Open File Report 96-08, 1996.
6. Historical Aerial Photos. <http://www.historicaerials.com>.
7. Jennings, C. W., 1994, California Division of Mines and Geology, *Fault Activity Map of California and Adjacent Areas*, California Geologic Data Map Series Map No. 6.
8. Kennedy, M. P. and S. S. Tan, 2007, *Geologic Map of the Oceanside 30'x60' Quadrangle, California*, USGS Regional Map Series Map No. 2, Scale 1:100,000.
9. Legg, M. R., J. C. Borrero, and C. E. Synolakis (2002), *Evaluation of Tsunami Risk to Southern California Coastal Cities*, 2002 NEHRP Professional Fellowship Report, dated January.
10. SEAOC web application, *OSHPD Seismic Design Maps*, <https://seismicmaps.org/>.
11. Unpublished reports, aerial photographs, and maps on file with Geocon Incorporated.
12. USGS computer program, *Seismic Hazard Curves and Uniform Hazard Response Spectra*, <http://geohazards.usgs.gov/designmaps/us/application.php>.
13. Unpublished reports and maps on file with Geocon Incorporated.
14. 1953 stereoscopic aerial photographs of the subject site and surrounding areas (AXN-8M-80 and 81).

E-2

**Off-Site
Descending
Slope
Consultation**



Project No. G2438-52-01

June 28, 2023

Torrey Pacific Corporation
171 Saxony Road, Suite 109
Encinitas, California 92024

Attention: Mr. Brian Staver

Subject: OFF-SITE DESCENDING SLOPE CONSULTATION
TORREY CREST – 1220-1240 MELBA ROAD AND 1190 ISLAND VIEW LANE
ENCINITAS, CALIFORNIA

- References:
1. *Geotechnical Investigation, Torrey Crest 1220-1240 Melba Road and 1190 Island View Lane, Encinitas, California*, prepared by Geocon Incorporated, revised April 5, 2023 (Project No. G2438-52-01).
 2. *Storm Water Management Investigation, Torrey Crest 1220-1240 Melba Road and 1190 Island View Lane, Encinitas, California*, prepared by Geocon Incorporated, revised March 21, 2022 (Project No. G2438-52-01).

Dear Mr. Staver:

In accordance with your request, we prepared this letter to provide consultation services regarding the descending slope that exists east of the subject development. The discussion presented herein is based on a site visit and discussions with neighbors on June 22, 2023.

SITE DESCRIPTION

Based on a review of our referenced report and our site visit, a slope descends on the eastern portion of the site to a single-family residence located at 246 Witham Road. The slope is about 18 feet high and is inclined at about 1.5:1 (horizontal to vertical). A city easement exists at the top of the slope that is about 8 to 10 feet wide that is relatively flat and possesses a concrete brow ditch that drains to the north. The easement continues north and crosses several properties.

The proposed residential development is located to the west of the existing residence and the city easement. The proposed improvements located near the top of the slope include a biofiltration basin to help with storm water management for the proposed development. The basin will be embedded about 5 feet below the existing grades and walls will extend up about 5 feet above existing elevations to provide the required grades for the basin. The basin will also be lined (waterproofed) as recommended in our referenced Storm Water Management Investigation dated March 21, 2022. We

understand the basin will be lined with either an appropriate liner or concrete. The Site Plan shows an excerpt of the subject areas from our Geologic Map presented in our referenced report dated April 9, 2023.

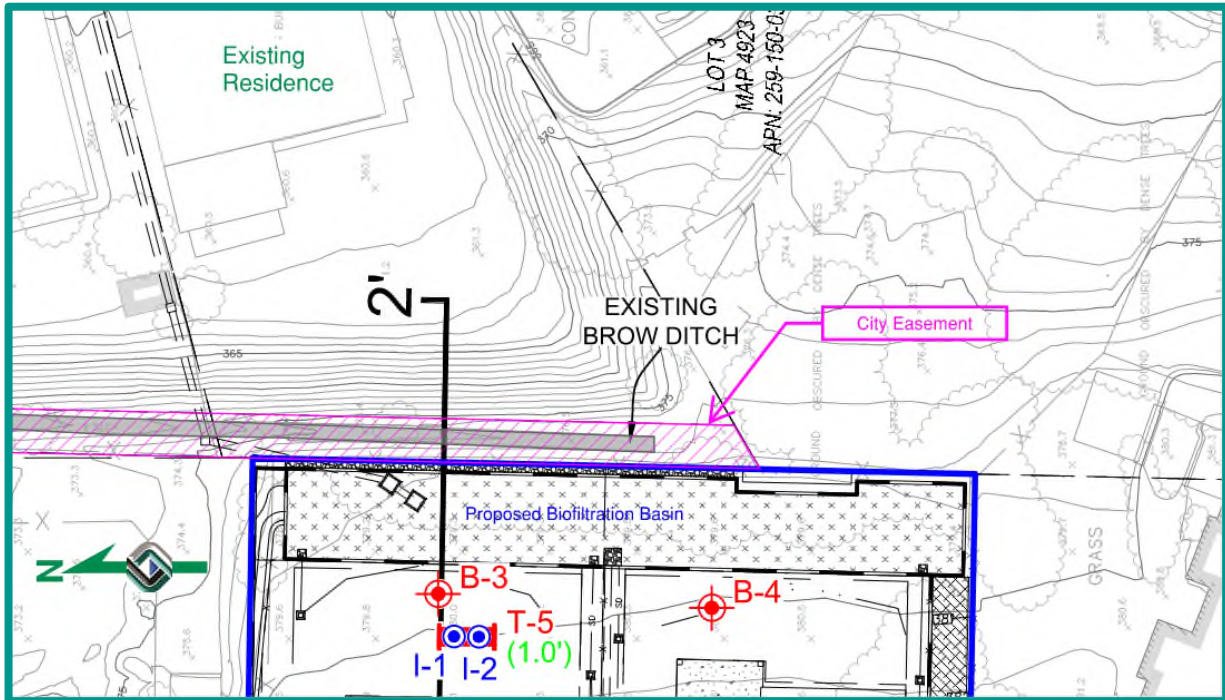

Site Plan (Excerpt from Geologic Map)

The descending slope exposed formational materials of the Very Old Paralic Deposits. The slope face consists of cemented zones and relatively loose to medium dense, silty sand. The slope appears to not be landscaped and consists of natural shrubs and grasses. Ice plant is located along the base of the slope. A small retaining wall exists at the base of the slope that consists of broken pieces of concrete with a maximum height of about 1 to 2 feet. The slope does not appear to be irrigated.

SLOPE STABILITY ANALYSES

We performed slope stability analyses using the two-dimensional computer program GeoStudio 2018 created by Geo-Slope International Ltd. We selected Cross-Section 2-2' to perform the slope stability analyses. We calculated the factor of safety for the planned slopes for rotational-mode and block-mode analyses using the Spencer's method.

We used average drained direct shear strength parameters based on laboratory tests and our experience with similar soil types in nearby areas for the slope stability analyses. Our calculations indicate the existing slope with the proposed development possesses a calculated factor of safety (FOS) of at least 1.5 under static conditions. Output of the computer program including the calculated factor of safety and the failure surface is presented herein.

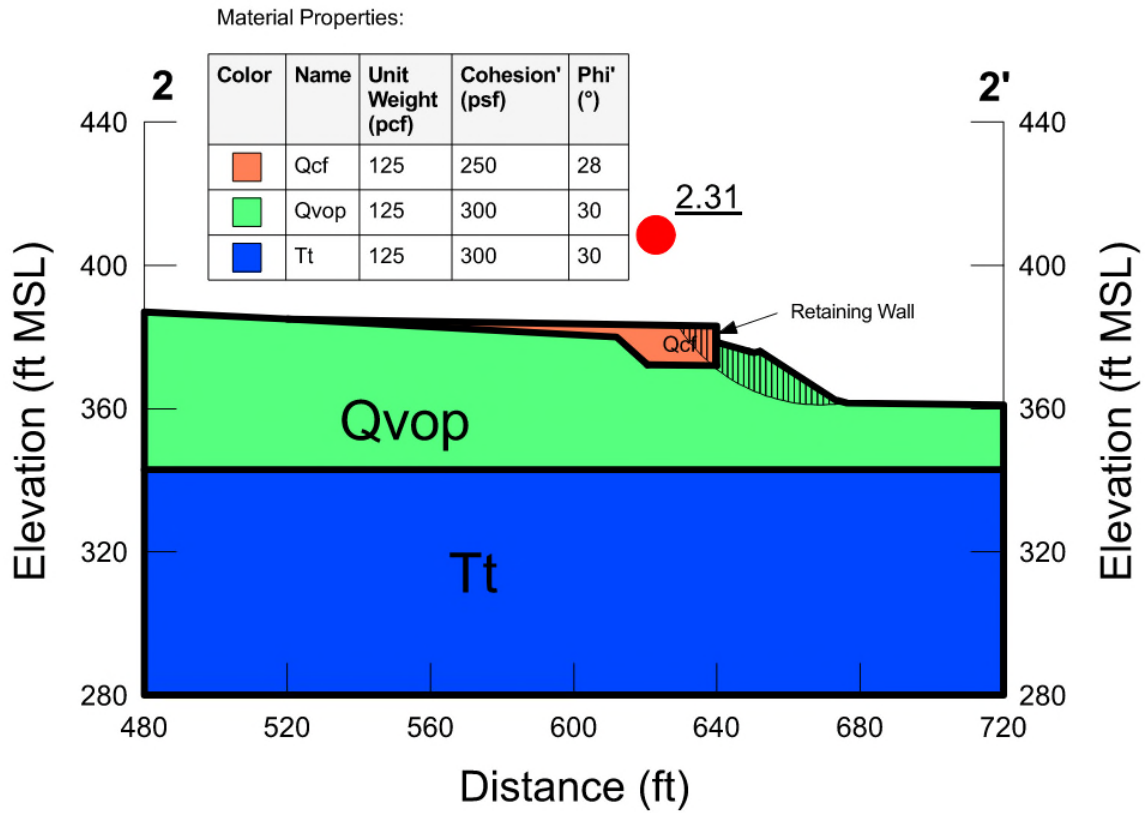

We also calculated the surficial slope stability analysis for the existing sloping conditions as summarized in the following table.

SURFICIAL SLOPE STABILITY EVALUATION

| Parameter | Value |
|---|----------------------|
| Slope Height, H | ∞ |
| Vertical Depth of Saturation, Z | 3 Feet |
| Slope Inclination, I (Horizontal to Vertical) | 1.5:1 (26.6 Degrees) |
| Total Soil Unit Weight, γ | 125 pcf |
| Water Unit Weight, γ_w | 62.4 pcf |
| Friction Angle, ϕ | 30 Degrees |
| Cohesion, C | 300 psf |
| Factor of Safety = $(C + (\gamma + \gamma_w)Z \cos^2 I \tan \phi) / (\gamma Z \sin I \cos I)$ | 2.2 |

CONCLUSIONS

Based on the discussion herein and the results of the slope stability analyses, the existing slope possesses a minimum factor of safety of at least 1.5 in accordance with the guidelines of the City of Encinitas. Therefore, the proposed development is acceptable from a geotechnical engineering standpoint. The proposed development will help control the flow of water toward the neighboring properties to the east by installing the proposed basin that will be waterproofed and connected to the storm drain system.

The existing slope exposes the Very Old Paralic Deposits that consists of cemented materials and weathered, relatively loose silty sand. The loose sandy portion of the slope possesses an abundant amount of krotovina (animal burrows). Water from rain events likely fills the voids, saturates the materials, and causes an increase in erosion. The property owner can employ a geotechnical engineer/landscape architect/contractor to provide recommendations for stabilizing the surficial stability of the slope, if desired. We would expect the slopes would be abated to handle additional animal burrows, be landscaped with drought-tolerant vegetation having variable root depths and requiring minimal landscape irrigation. In addition, slopes should be drained and properly maintained to reduce erosion.

If you have any questions regarding this letter, or if we may be of further service, please contact the undersigned at your convenience.

Very truly yours,

GEOCON INCORPORATED



Shawn Foy Weedon
GE 2714



SFW:arm

(e-mail) Addressee